



MEDICAL CARE DRIVE SOLUTIONS

BIBUS ENDÜSTRİYEL A.Ş.

İkitelli OSB Bedrettin Dalan Bulvarı Vip Plaza
Kat:2 No:43 Başakşehir/İstanbul

Tel. 444 20 38
Fax 0212 249 88 34

info@bibus.com.tr
www.bibus.com.tr



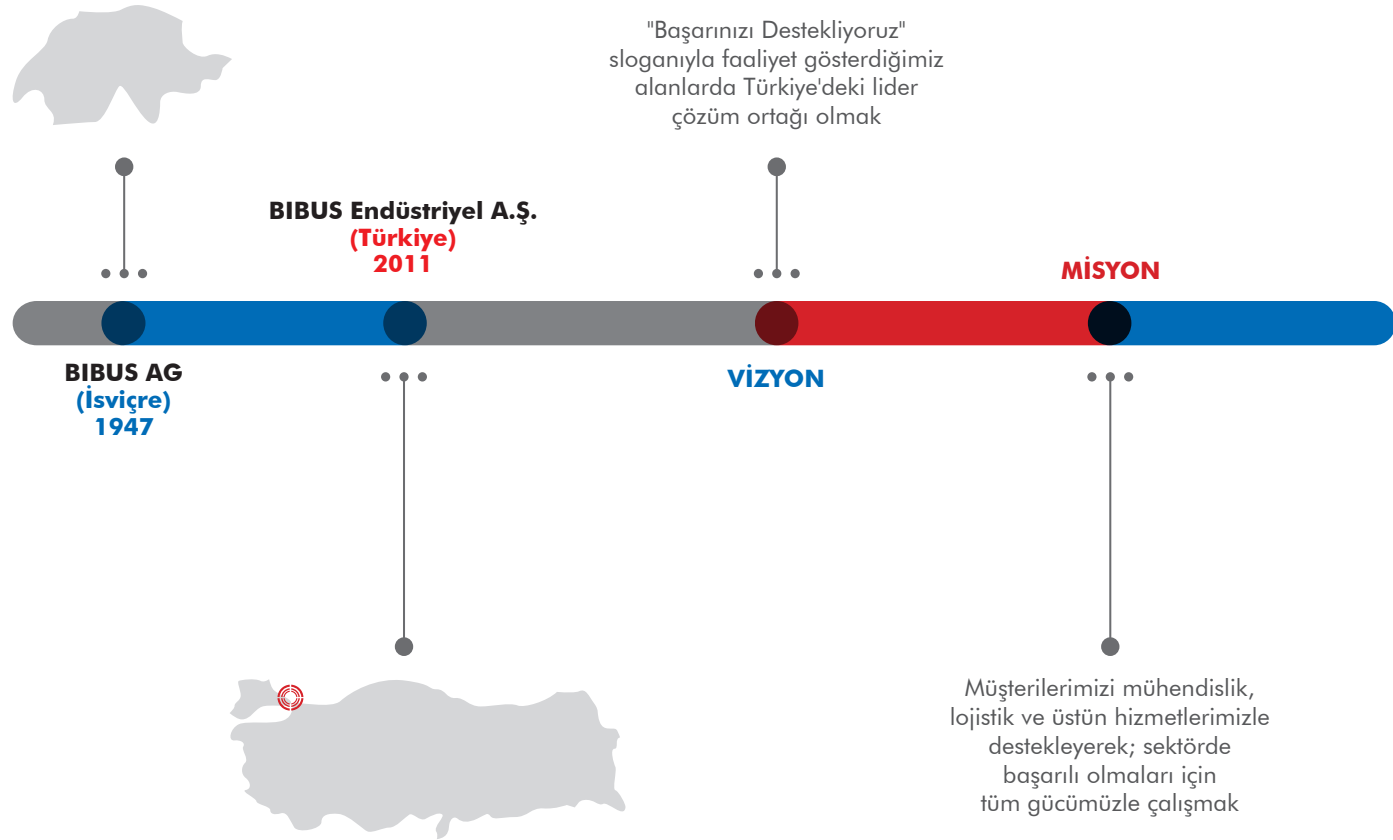

BIBUS Türkiye

Başarınızı destekliyoruz

TEK TEDARİKÇİ • TEK TEMAS • TEK SORUMLULUK

BIBUS Holding AG, Avrupa ve Asya'daki lokasyonları ile birlikte İsviçre merkezli bir şirkettir. 1947 yılında Dipl. Ing. Hans Bibus tarafından, çelik ticareti amacı ile kurulmuş olan şirket; teknoloji, malzeme ve elektronik alanlarında faaliyet gösteren ilerici bir şirketler grubuna dönüşmüştür. Güvenilirliği ve yüksek kalite standartları sayesinde, yüksek kaliteli endüstriyel ürünler, bileşenler ve sistem çözümleri için pazarda lider tedarikçi ve hizmet ortağı olarak kendini kanıtlamıştır.

BIBUS Holding AG, iç ve dış ortaklarıyla birlikte büyür ve başarılarını güçlü bir şekilde destekler. Tüm şubeler, grubun uzmanlığına ve kaynaklarına erişebilir. Kendileri için, mühendislik, lojistik ve hizmet segmentlerindeki özel yerel yetkinlikleri ile müşterilerimizin ve tedarikçilerimizin performansına katkıda bulunurlar.

Ortaklarımız, genel müdürlerimiz ve çalışanlarımızla birlikte, "Başarınızı destekliyoruz" ilkemize dayanarak uzun vadeli istikrarlı bir geleceğe bağlıyız.

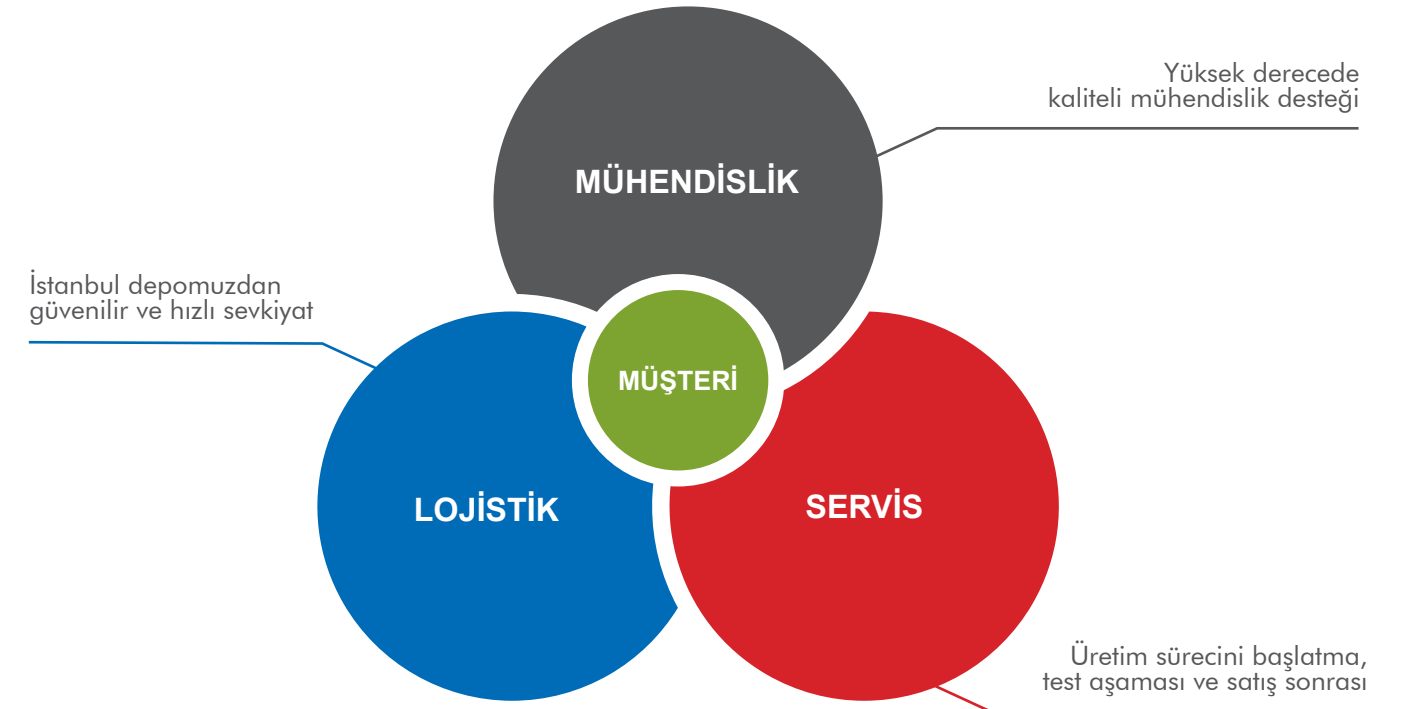

www.bibus.com.tr

BIBUS Advantage



Professional and efficient customization

Both software and hardware can be customized to meet customer needs. For example, the actuator specifications can be adjusted according to the application and the software for special function can be developed. Our efficient development team allows your products to win market opportunities.



Targeted development for the global market

Refine the product market and develop products targeted for a wide range of applications. Our endcustomers involve multiple industries and all over the world.



Can-Bus communication protocol

BIBUS specially developed Can-Bus communication protocol, enabling manufacturers to easily and smoothly integrate intelligent and reliable movement with control system. It allows to provide more functions to the customer's control system.



Strictly comply with medical safety regulations

Medical products are committed to the EMC testing requirements of domestic medical devices, and the products comply with ISO9001:2015 and ISO14001:2015 management systems. Export products have passed CE, UL, CE, RoHS, PSE, SAA and other international approvals to ensure that your products meet the standards of various countries.



Global pre-sales and after-sales service

Our branches are located in Europe, America, and Asia Pacific. We can reply to you within 24 hours, give feedback or propose solutions within 48 hours. BIBUS provides a 5-year warranty service.



Solutions to ensure safety

Our IPX6 rated products are washable and easy to clean. Anti-pitch solution, quick release solution and anti-collision solution ensure the safety of users. Twenty thousand fatigue tests ensure the stability of the system.

Actuator System for ICU bed

1. Specially developed for the ICU bed system, the three-column system structure makes the bed design simpler, easily realizes various examinations in the bed, and reduces the secondary injury of severely ill patients
2. It is equipped with more operation function requirements and easy to achieve the operation of each position
3. Equipped with CAN-BUS system, it can achieve more functional requirements and connect outer expansion equipment



JCHN35E1



Newly upgraded guardrail



JCF35V

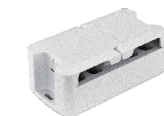
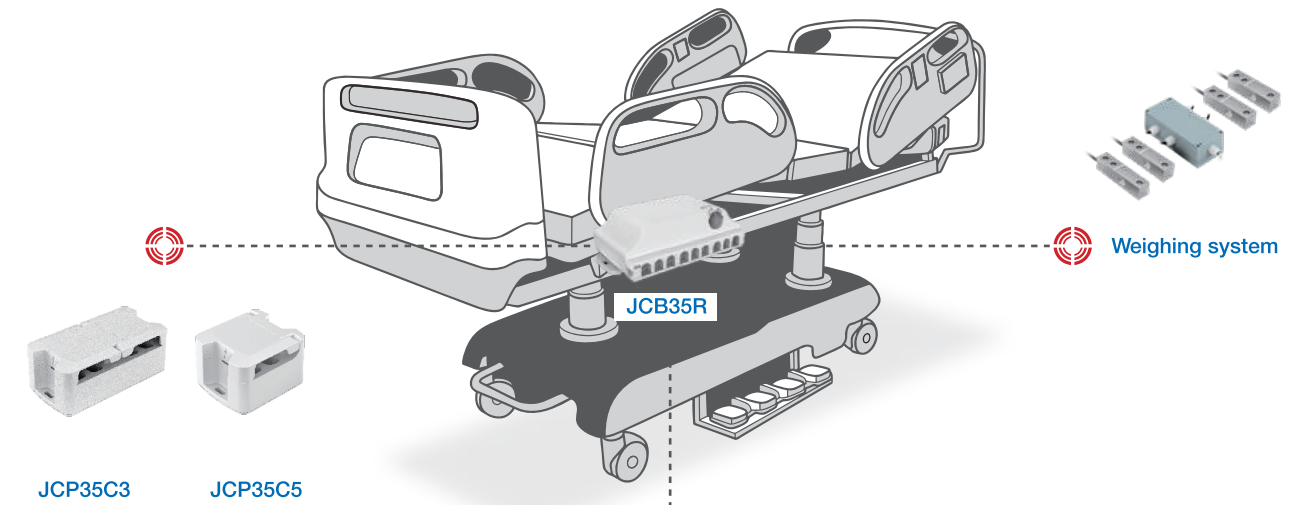

JCP35C3



JCP35C5



Weighing system



JC35L9



JC35L10



JC35EG

Actuator System for Hospital bed

1. Equipped with CAN-BUS system, it can achieve more functional requirements and connect outer expansion equipment
2. Equipped with weighing and guardrail operating system and it makes weight monitoring and operation simpler
3. With electronic and mechanical CPR, emergency stop switch function then the rescue could do more timely and the operation is safer

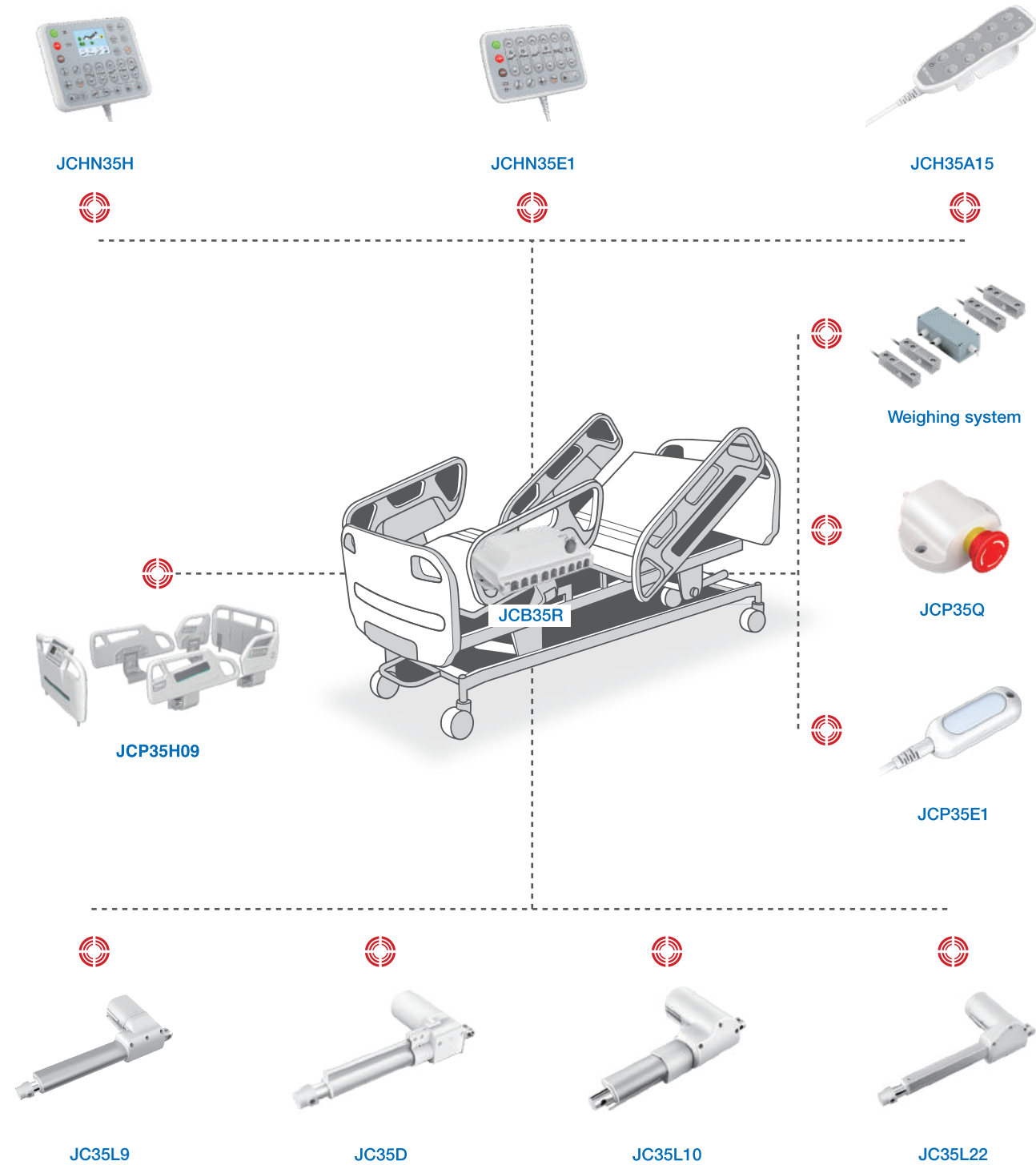

Actuator System for Bath lift

1. IPX8 high waterproof performance
2. Widen flap seat cushion provide comfortable use space
3. Foldable, easy carrying
4. The bottom of the seat is equipped with 6 powerful suction cups with easy pull tag.
5. After full charged, it can run continuously more than 10 times



Actuator System for Patient lift

1. Lithium battery design, its service life and frequency are more excellent than lead-acid batteries
2. The control system can record actuator using times and remind the system maintenance
3. Both external charger charging and in-line charging can be chosen
4. Complete sets of systems is up to IPX6 waterproof
5. Optional magnetic handset is more convenient to fix

Option A



JC35K1



JCB35K2-A



JCH35V2

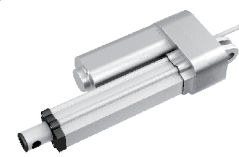
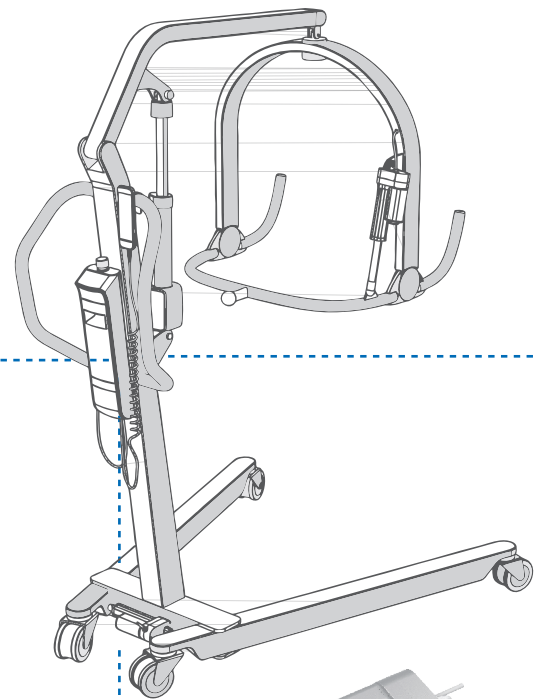

JC35W2-2

Option B



JC35L12



JCB35K3



JCH35A10

Actuator System for Home-care bed

1. Economical system, easy to achieve nursing needs and reduce the intensity of nursing work
2. The handset is equipped with silicone buttons, which adopts to the user's habits
3. Optional power separation system is safer to use

Option A



JC35L22



JCB35Q



JCH35A19

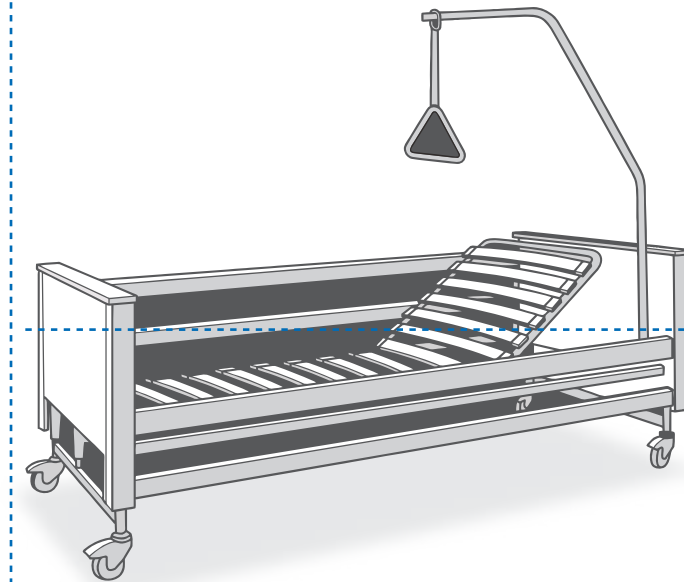

Option B



JC35L9



JCB35T



JCH35A18

JC35L9

LINEAR ACTUATOR

Feature

- Max. load push(N): 6000
- Max. load pull(N): 4000
- Max. speed at full load(mm/s): 6
- Installation dimensions:
L=225(S≤50)
L=S+175(50<S≤200)
L=S+185(200<S≤300)
L=S+195(300<S≤400)
L=S+205(400<S≤500)
- IP grade: Max . IPX6
- Option:
Only push no pull
Hall sensor
Reed switch
Safety nut

Approval

- 1.ANSI/AAMI ES60601-1:2005/(R)2012
and A1:2012, C1:2009/(R)2012
and A2:2010/(R)2012
- 2.EN 60601-1:2006+A12:2014
- 3.IEC60601-1:2012



Technical specifications

Voltage (VDC)	Spindle pitch (mm)	Max. load in push (N)	Max. load in pull (N)	Mechanical self-lock (N)	Speed at no load /full load (mm/s)	Current at full load (A)
24	4	6000	4000	6000	6.0/3.6	≤6.0
	5	4000	/	4000	7.5/5.3	≤5.5
	5	6000	4000	6000	7.5/4.5	≤6.5
	4	6000	4000	6000	3.8/2.4	≤4.5
29	4	6000	4000	6000	7.3/4.3	≤6.0
	5	4000	/	4000	9.0/6.4	≤5.5
	5	6000	4000	6000	9.0/5.4	≤6.5
	4	6000	4000	6000	4.6/2.9	≤4.5

Remarks: It can achieve better self-locking ability with Bibus control box;
The above data is the standard value of the test data (inspection specification) at room temperature of 25°C.

JC35L10

LINEAR ACTUATOR

Feature

- Max. load push(N): 4000
- Dynamic load pull(N): 3500
- Max. speed(mm/s): 8
- Installation dimensions:
L=235(30≤S<50)
L=S+185(50≤S≤400)
- IP grade: IP54
- Option:
Quick release (standard)
Only push no pull
Hall sensor
Safety nut

Approval

- 1.ANSI/AAMI ES60601-1:2005/(R)2012
and A1:2012, C1:2009/(R)2012
and A2:2010/(R)2012
- 2.EN 60601-1:2006+A12:2014
- 3.IEC60601-1:2012



Technical specifications

Voltage (VDC)	Spindle pitch (mm)	Max. load in push (N)	Max. load in pull (N)	Mechanical self-lock (N)	Speed at no load /full load (mm/s)	Current at full load (A)
24	5	4000	3500	3500	6.5/5.0	≤4.5
	6	3000	3000	2500	8.5/6.5	≤4.5
29	5	4000	3500	3500	8.0/6.0	≤4.5
	6	3000	3000	2500	9.5/8.0	≤4.5

Remarks: It can achieve better self-locking ability with Bibus control box;
The above data is the standard value of the test data (inspection specification) at room temperature of 25°C.

JC35D

LINEAR ACTUATOR

Feature

- Max. load push(N): 6000
- Max. speed: 43.2
- Installation dimensions:
L=225(S<50)
L=S+175(50≤S<400)
L=S+195(S≥400)
- IP grade: IP43
- Option:
Only push no pull
Hall sensor
Reed switch

Approval

- 1.ANSI/AAMI ES60601-1:2005/(R)2012 and A1:2012,C1:2009/(R)2012 and A2:2010/(R)2012
- 2.EN 60601-1:2006+A12:2014
- 3.IEC60601-1:2012

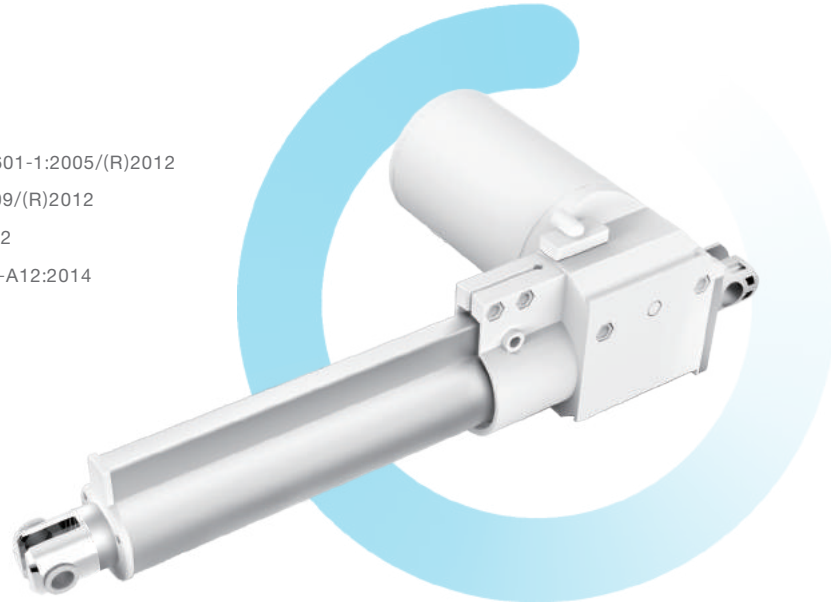

Technical specifications

Voltage (VDC)	Spindle pitch (mm)	Max. load in push (N)	Max. load in pull (N)	Mechanical self-lock (N)	Speed at no load /full load (mm/s)	Current at full load (A)
24	16	750	/	500	45.0/36.0	≤1.5
	12	1000	/	800	32.8/25.0	≤1.5
	7.5	1500	/	1500	20.4/16.0	≤1.5
	5	2000	/	3000	13.9/11.0	≤1.2
	7.5	3000	/	3000	8.6/6.5	≤0.7
	5	4000	/	4000	5.8/4.0	≤0.7
	4	6000	/	6000	4.6/3.4	≤0.7
	4	6000	/	6000	6.1/4.1	≤0.7
29	5	6000	/	6000	6.0/4.6	≤0.7
	16	750	/	500	54.0/43.2	≤1.5
	12	1000	/	800	39.3/30.0	≤1.5
	7.5	1500	/	1500	24.5/19.2	≤1.5
	5	2000	/	3000	16.7/13.2	≤1.2
	7.5	3000	/	3000	10.4/7.8	≤0.7
	5	4000	/	4000	7.0/4.8	≤0.7
	4	6000	/	6000	5.5/4.1	≤0.7
	4	6000	/	6000	7.3/4.9	≤0.7
	5	6000	/	6000	7.2/5.5	≤0.7

Remarks: It can achieve better self-locking ability with Bibus control box;
The above data is the standard value of the test data (inspection specification) at room temperature of 25°C.

JC35DF

LINEAR ACTUATOR

Feature

- Max. load push(N): 6000
- Max. load pull(N): 4000
- Max. speed(mm/s): 36
- Installation dimensions:
L=225(S≤50)
L=S+175(50<S<400)
L=S+195(400≤S<600)
- IP grade: Max. IP66
- Option:
Only push no pull
Hall sensor
Reed switch

Approval

- 1.ANSI/AAMI ES60601-1:2005/(R)2012 and A1:2012, C1:2009/(R)2012 and A2:2010/(R)2012
- 2.EN 60601-1:2006+A12:2014
- 3.IEC60601-1:2012



Technical specifications

Voltage (VDC)	Spindle pitch (mm)	Max. load in push (N)	Max. load in pull (N)	Mechanical self-lock (N)	Speed at no load /full load (mm/s)	Current at full load (A)
24	4	6000	4000	6000	5.5/3	≤4.5
	5	4000	4000	4000	6.8/4	≤4
	7.5	3000	3000	3000	10.2/6	≤4
	5	2000	2000	2000	13.6/9	≤4
	7.5	1500	1500	1500	20.5/13	≤4.5
	12	1000	1000	1000	33/22	≤4
	16	500	500	500	44/25	≤4
	29	4	6000	4000	6000	6.7/3.8
5		4000	4000	4000	8.2/5.2	≤4
7.5		3000	3000	3000	12/7.5	≤4
5		2000	2000	2000	16/11	≤4
7.5		1500	1500	1500	25/16.5	≤4.5
12		1000	1000	1000	40/26	≤4
16		500	500	500	53/36	≤4

Remarks: It can achieve better self-locking ability with Bibus control box;
The above data is the standard value of the test data (inspection specification) at room temperature of 25°C.

JC35L22

LINEAR ACTUATOR

Feature

- Max. load push(N): 6000
- Max. load pull(N): 4000
- Max. speed(mm/s): 6.3
- Installation dimensions:
Standard:
6000N/4000N:
L=225 (25≤S<50)
L=S+175 (50≤S<200)
2500N(Long stroke, only used in heli-helical applications):
L=225 (25≤S<50)
L=S+175 (50≤S<200)
L=S+185(200≤S≤415)
Hand crank:
6000N/4000N:
L=S+175 (50≤S≤200)
- IP grade: Max. IP66 (Hand crank: IP20)
- Option:
Only push no pull
Hand crank function

Approval

- 1.ANSI/AAMI ES60601-1:2005/(R)2012
and A1:2012, C1:2009/(R)2012
and A2:2010/(R)2012
- 2.EN 60601-1:2006+A12:2014
- 3.IEC60601-1:2012



Technical specifications

Voltage (VDC)	Spindle pitch (mm)	Max. load in push (N)	Max. load in pull (N)	Mechanical self-lock (N)	Speed at no load /full load (mm/s)	Current at full load (A)
29	3	6000	4000	6000	4.3/2.6	≤4.2
	2.5	6000	4000	6000	7.7/3.8	≤5.5
	4	4000	4000	4000	6.0/4.0	≤5.0
	4	2500	2000	2500	8.0/6.0	≤5.0

Remarks: It can achieve better self-locking ability with Bibus control box;
The above data is the standard value of the test data (inspection specification) at room temperature of 25°C.

JC35L23

LINEAR ACTUATOR

Feature

- Max. load push(N): 6000
- Max. speed(mm/s): 7
- Installation dimensions:
L=S+185(50≤S≤300)
L=S+195(50≤S≤300,with anti-pitch option)
- IP grade: Max. IPX6
- Option:
Quick release (standard)
Only push no pull
Hall sensor
Safety nut

Approval

- 1.ANSI/AAMI ES60601-1:2005/(R)2012
and A1:2012, C1:2009/(R)2012
and A2:2010/(R)2012
- 2.EN 60601-1:2006+A12:2014
- 3.IEC60601-1:2012



Technical specifications

Voltage (VDC)	Spindle pitch (mm)	Max. load in push (N)	Max. load in pull (N)	Mechanical self-lock (N)	Speed at no load /full load (mm/s)	Current at full load (A)
24	6	6000	/	6000	6.0/4.5	≤4.5
29	6	6000	/	6000	7.0/5.5	≤4.5
36	6	6000	/	6000	9.0/7.0	≤4.5

Remarks: It can achieve better self-locking ability with Bibus control box;
The above data is the standard value of the test data (inspection specification) at room temperature of 25°C.

JC35L3

LINEAR ACTUATOR

Feature

- Max. load push(N): 6000
- Max. load pull(N): 4000
- Max. speed(mm/s): 9.6
- Installation dimensions:
L=225(L≤50)
L=S+175(S≤200)
L=S+185(200<S≤400)
- IP grade: Max. IPX6
- Option:
Only push no pull
Hall sensor
Safety nut

Approval

- 1.ANSI/AAMI ES60601-1:2005/(R)2012 and A1:2012, C1:2009/(R)2012 and A2:2010/(R)2012
- 2.EN 60601-1:2006+A12:2014
- 3.IEC60601-1:2012



Technical specifications

Voltage (VDC)	Spindle pitch (mm)	Max. load in push (N)	Max load in pull (N)	Mechanical self-lock (N)	Speed at no load /full load (mm/s)	Current at full load (A)
24	4	6000	4000	6000	5.7/4.0	≤5.5
	5	4000	4000	4000	6.8/5.1	≤5.0
	7.5	3000	3000	3000	11.0/8.0	≤5.0
29	4	6000	4000	6000	7.2/5.0	≤5.0
	5	4000	4000	4000	8.1/6.5	≤4.5
	7.5	3000	3000	3000	13.2/9.6	≤4.5

Remarks: It can achieve better self-locking ability with Bibus control box;
The above data is the standard value of the test data (inspection specification) at room temperature of 25°C.

JC35L18

LINEAR ACTUATOR

Feature

- Max. load push(N): 8000
- Max. speed(mm/s): 18
- Installation dimensions:
Standard:
L=225(S≤50)
L=S+175(50<S≤400)
L=S+195(400<S≤500)
Fast version:
L=225(S≤50)
L=S+175(50<S≤200)
L=S+185(200<S≤300)
- IP grade: Max . IPX6W
- Option:
Only push no pull
Hall sensor
Safety nut

Approval

- 1.ANSI/AAMI ES60601-1:2005/(R)2012 and A1:2012, C1:2009/(R)2012 and A2:2010/(R)2012
- 2.EN 60601-1:2006+A12:2014
- 3.IEC60601-1:2012

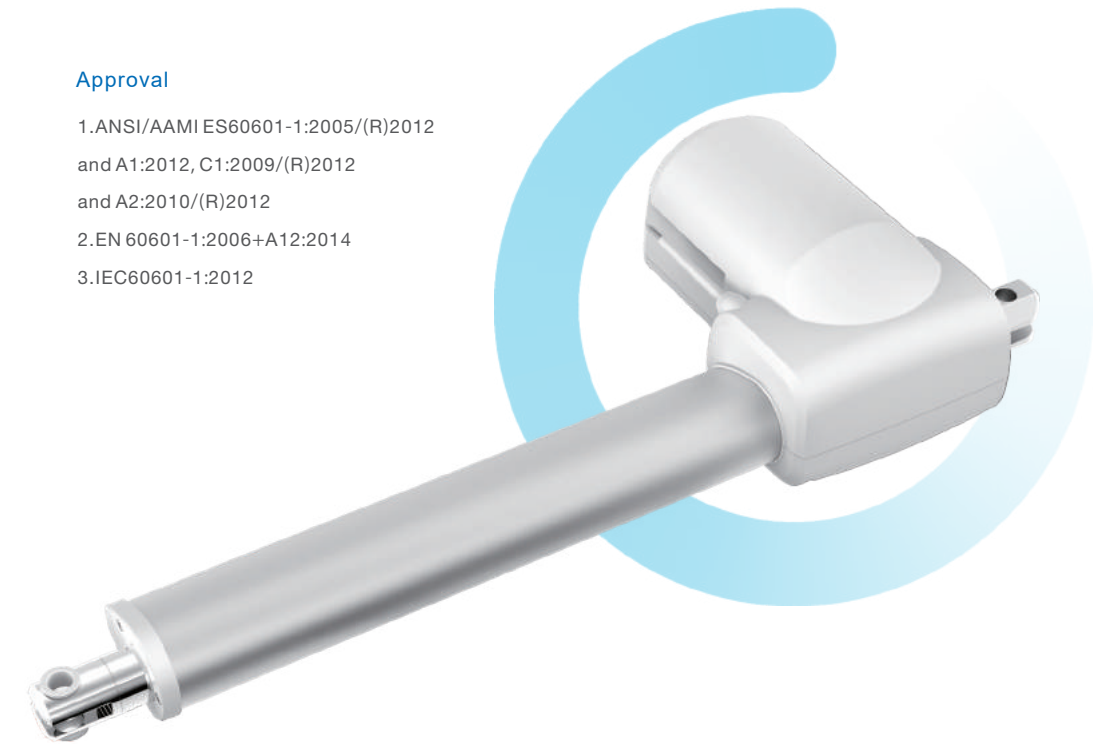

Technical specifications

Voltage (VDC)	Spindle pitch (mm)	Max. load in push (N)	Max. load in pull (N)	Mechanical self-lock (mm)	Speed at no load /full load (mm/s)	Current at full load (A)
24	3	8000	/	8000	4.4/3.0	≤6.0
	4	6000	/	6000	5.5/4.0	≤5.0
	12	6000	/	6000	21.0/12.0	≤11.5
	12	5000	/	5000	21.0/13.0	≤10.0
	12	4000	/	4000	21.0/14.0	≤8.0
	12	3000	/	3000	21.0/15.0	≤6.0
29	3	8000	/	8000	5.3/4.0	≤6.0
	4	6000	/	6000	7.2/5.5	≤5.0
	12	6000	/	6000	25.0/14.4	≤11.5
	12	5000	/	5000	25.0/15.6	≤10.0
	12	4000	/	4000	25.0/16.8	≤8.0
	12	3000	/	3000	25.0/18.0	≤6.0
36	3	8000	/	8000	6.5/5.0	≤6.0
	4	6000	/	6000	9.0/7.0	≤5.0

Remarks: It can achieve better self-locking ability with Bibus control box;
The above data is the standard value of the test data (inspection specification) at room temperature of 25°C.

JC35L28

LINEAR ACTUATOR

Feature

- Max. load push(N): 10000
- Max. speed(mm/s): 7.3
- Installation dimensions:
L=235(20≤S≤50, standard)
L=S+185(50<S≤250, standard)
L=S+260(50<S<300, manual operation)
L=S+290(300≤S≤400, manual operation)
- IP grade: Max. IPX6
- Option:
Only push no pull
Hall sensor
Manual operation
Safety nut

Approval

- 1.ANSI/AAMI ES60601-1:2005/(R)2012
and A1:2012, C1:2009/(R)2012
and A2:2010/(R)2012
- 2.EN 60601-1:2006+A12:2014
- 3.IEC60601-1:2012

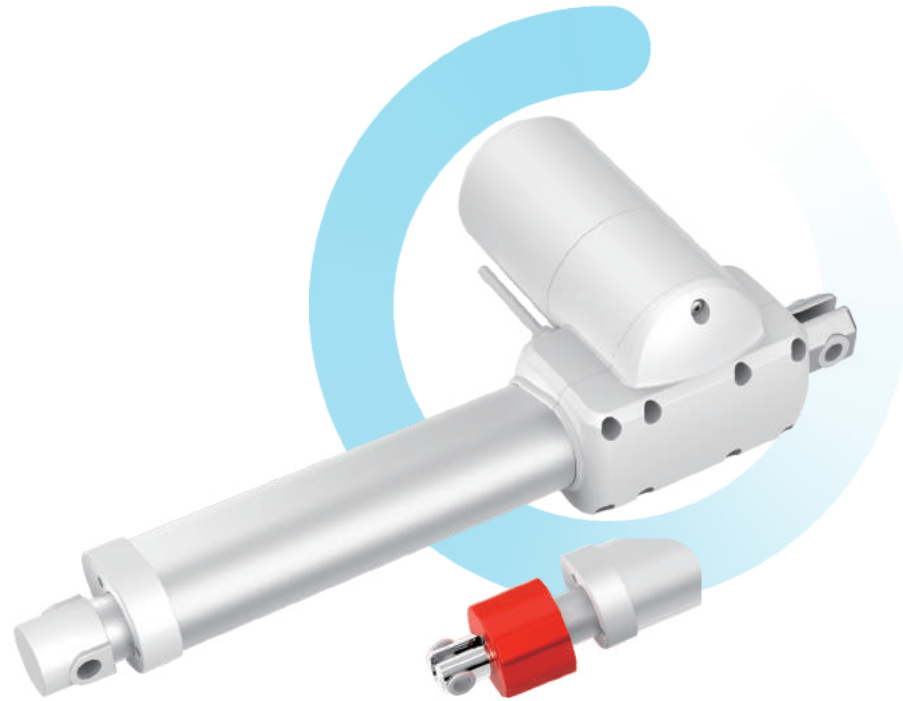

Technical specifications

Voltage (VDC)	Spindle pitch (mm)	Max. load in push (N)	Max. load in pull (N)	Mechanical self-lock (N)	Speed at no load /full load (mm/s)	Current at full load (A)
24	6	10000	/	10000	6.0/4.0	≤7.0
	6	8000	/	8000	8.0/5.5	≤6.0
29	6	10000	/	10000	7.5/5.5	≤7.5
	6	8000	/	8000	10.0/7.3	≤7.0

Remarks: It can achieve better self-locking ability with Bibus control box;
The above data is the standard value of the test data (inspection specification) at room temperature of 25°C.

JC35K1

LINEAR ACTUATOR

Feature

- Max. load push(N): 8000
- Max. speed: 4
- Installation dimensions:
L=S+260(S≤300)
- IP grade: IP54
- Option:
Only push no pull
Manual operation
Safety nut

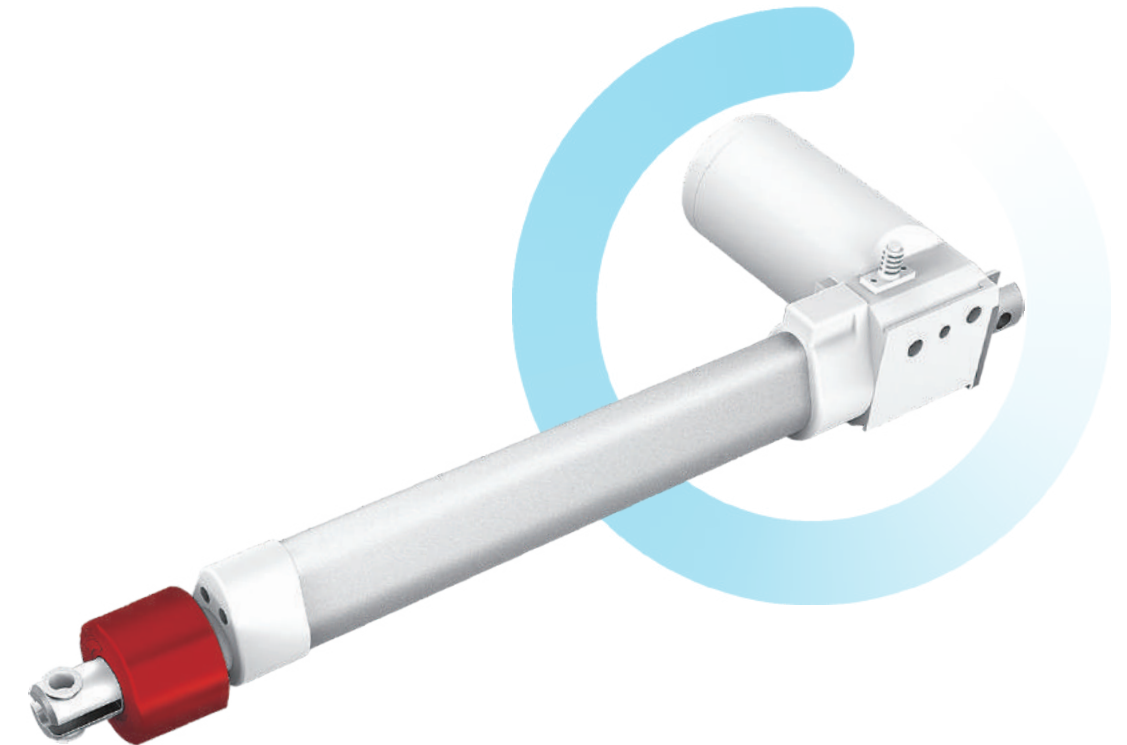

Technical specifications

Voltage (VDC)	Spindle pitch (mm)	Max. load in push (N)	Max. load in pull (N)	Mechanical self-lock (N)	Speed at no load /full load (mm/s)	Current at full load (A)
24	3	8000	/	8000	5.8/3.3	7.0
29	3	8000	/	8000	7.0/4.0	7.0

Remarks: It can achieve better self-locking ability with Bibus control box;
The above data is the standard value of the test data (inspection specification) at room temperature of 25°C.

JC35L29

LINEAR ACTUATOR

Feature

- Max. load push(N): 8000
- Dynamic load pull(N): 4000
- Max. speed(mm/s): 3.5
- Installation dimensions:
L=S+175(50<S≤200)
L=S+185(200<S≤250)
- IP grade: Max. IPX6
- Option:
Hall sensor
Reed switch
Safety nut

Approval

- 1.ANSI/AAMI ES60601-1:2005/(R)2012
and A1:2012, C1:2009/(R)2012
and A2:2010/(R)2012
- 2.EN 60601-1:2006+A12:2014
- 3.IEC60601-1:2012



Technical specifications

Voltage (VDC)	Spindle pitch (mm)	Max. load in push (N)	Max. load in pull (N)	Mechanical self-lock (N)	Speed at no load /full load (mm/s)	Current at full load (A)
24	3	8000	/	8000	4.0/3.0	≤6.0
29					5.0/3.5	≤6.0

Remarks: It can achieve better self-locking ability with Bibus control box;
The above data is the standard value of the test data (inspection specification) at room temperature of 25°C.

JC35L30

LINEAR ACTUATOR

Feature

- Max. load push(N): 6000N
- Max. load pull(N): 4000N
- Max. speed(mm/s): 6.5
- Installation dimensions:
L=S+175(50<S≤200)
L=S+185(200<S≤400)
- IP grade: Max. IPX6
- Option:
Only push no pull
Hall sensor
Safety nut

Approval

- 1.ANSI/AAMI ES60601-1:2005/(R)2012
and A1:2012, C1:2009/(R)2012
and A2:2010/(R)2012
- 2.EN 60601-1:2006+A12:2014
- 3.IEC60601-1:2012



Technical specifications

Voltage (VDC)	Spindle pitch (mm)	Max. load in push (N)	Max. load in pull (N)	Mechanical self-lock (N)	Speed at no load /full load (mm/s)	Current at full load (A)
24	4	6000	4000	6000	5.7/4.0	≤5.0
	5	4000	4000	4000	7.2/5.4	≤4.0
29	4	6000	4000	6000	6.8/4.8	≤5.0
	5	4000	4000	4000	8.6/6.5	≤4.0

Remarks: It can achieve better self-locking ability with Bibus control box;
The above data is the standard value of the test data (inspection specification) at room temperature of 25°C.

JC35L9

LINEAR ACTUATOR

Feature

- Max. load push(N): 6000
- Max. load pull(N): 4000
- Max. speed at full load(mm/s): 6
- Installation dimensions:
L=225(S≤50)
L=S+175(50<S≤200)
L=S+185(200<S≤300)
L=S+195(300<S≤400)
L=S+205(400<S≤500)
- IP grade: Max . IPX6
- Option:
Only push no pull
Hall sensor
Reed switch
Safety nut

Approval

- 1.ANSI/AAMI ES60601-1:2005/(R)2012 and A1:2012, C1:2009/(R)2012 and A2:2010/(R)2012
- 2.EN 60601-1:2006+A12:2014
- 3.IEC60601-1:2012

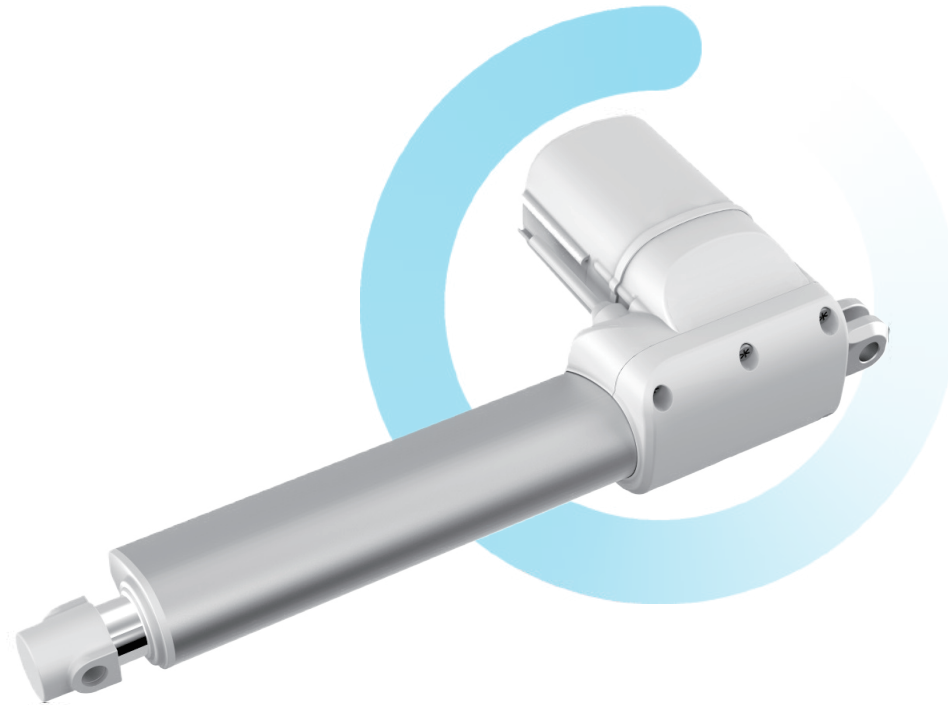

Technical specifications

Voltage (VDC)	Spindle pitch (mm)	Max. load in push (N)	Max. load in pull (N)	Mechanical self-lock (N)	Speed at no load /full load (mm/s)	Current at full load (A)
24	4	6000	4000	6000	6.0/3.6	≤6.0
	5	4000	/	4000	7.5/5.3	≤5.5
	5	6000	4000	6000	7.5/4.5	≤6.5
	4	6000	4000	6000	3.8/2.4	≤4.5
29	4	6000	4000	6000	7.3/4.3	≤6.0
	5	4000	/	4000	9.0/6.4	≤5.5
	5	6000	4000	6000	9.0/5.4	≤6.5
	4	6000	4000	6000	4.6/2.9	≤4.5

Remarks: It can achieve better self-locking ability with Bibus control box;
The above data is the standard value of the test data (inspection specification) at room temperature of 25°C.

JC35L6

LINEAR ACTUATOR

Feature

- Max. load push(N): 3000
- Max. load pull(N): 2000
- Max. speed: 63
- Installation dimensions:
Inner tube drilling with top clevis sleeve and top clevis bush
L=S+130 (S≤200)
L=S+140 (200<S≤300)
L=S+150 (300<S≤400)
L=S+160 (400<S≤500)
L=S+170 (500<S≤600)
With B type top clevis
L=S+160 (S≤200)
L=S+170 (200<S≤300)
L=S+180 (300<S≤400)
L=S+190 (400<S≤500)
L=S+200 (500<S≤600)
- IP grade: IP54
- Option:
Only push no pull
Hall sensor

Approval

- 1.ANSI/AAMI ES60601-1:2005/(R)2012 and A1:2012, C1:2009/(R)2012 and A2:2010/(R)2012
- 2.EN 60601-1:2006+A12:2014
- 3.IEC60601-1:2012

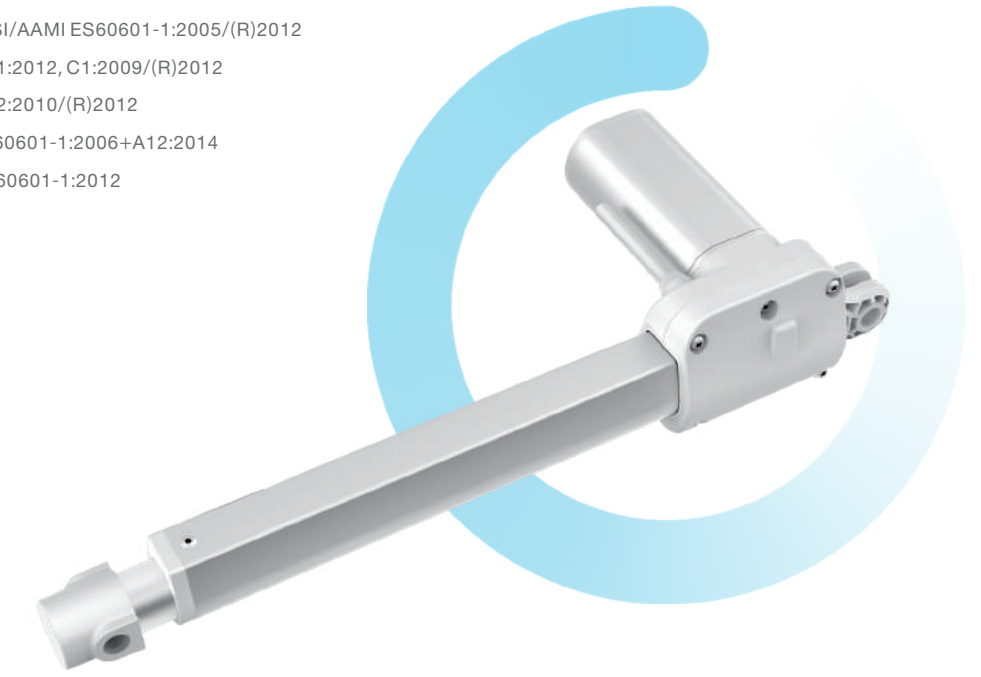

Technical specifications

Voltage (VDC)	Rotate speed (rpm)	Spindle pitch (mm)	Max. load in push (N)	Mechanical self-lock (N)	Speed at no load /full load (mm/s)	Current at full load (A)
12	Standard	7.5	1000	1000	15.0/10.0	≤6.0
24	Standard	3	3000	3000	6.5/4.5	≤4.0
		5	2000	2000	11.0/8.0	≤4.0
		7.5	1000	1000	15.0/13.0	≤3.0
		20	50	50	43.0/42.0	≤2.0
	Fast (small motor)	7.5	1000	1000	20.0/15.0	≤3.0
		20	50	50	49.0/47.0	≤2.0
29	Standard	3	3000	3000	8.0/5.5	≤4.0
		5	2000	2000	13.5/9.0	≤4.0
		7.5	1000	1000	20.0/17.0	≤3.0
		20	50	50	57.0/56.0	≤2.0
		Fast (small motor)	7.5	1000	1000	24.0/18.0
			20	50	50	66.0/63.0

Remarks: It can achieve better self-locking ability with Bibus control box;
The above data is the standard value of the test data (inspection specification) at room temperature of 25°C.

JC35L16

LINEAR ACTUATOR

Feature

- Max. load push(N): 6000
- Max. load pull(N): 4000
Max. speed: 3.3
- Installation dimensions:
L≥S+150(50≤S≤200)
L≥S+160(200<S≤300)
- IP grade: IP20
- Option:
Only push no pull(Standard)
Hall sensor

Approval

- 1.IEC60335-1:2012
- 2.EN60335-1:2012+A11:2014+A13:2017+A1:2019+A14:2019+A2:2019
- 3.UL962



Technical specifications

Voltage (VDC)	Spindle pitch (mm)	Max. load in push (N)	Max. load in pull (N)	Mechanical self-lock (N)	Speed at no load /full load (mm/s)	Current at full load (A)
24	3	6000	4000	6000	3.7/2.7	≤3.5
29	3	6000	4000	6000	4.5/3.3	≤3.5

Remarks: It can achieve better self-locking ability with Bibus control box;
The above data is the standard value of the test data (inspection specification) at room temperature of 25°C.

JC35L31

LINEAR ACTUATOR

Feature

- Max. load push(N): 4500
- Max. speed(mm/s): 8
- Installation dimensions:
4500N: L=S+135(50<S≤200)
2500N: L=S+135(50<S≤415)
- IP grade: IP20
- Option:
Only push no pull
Hall sensor

Approval

- 1.ANSI/UL962-2020

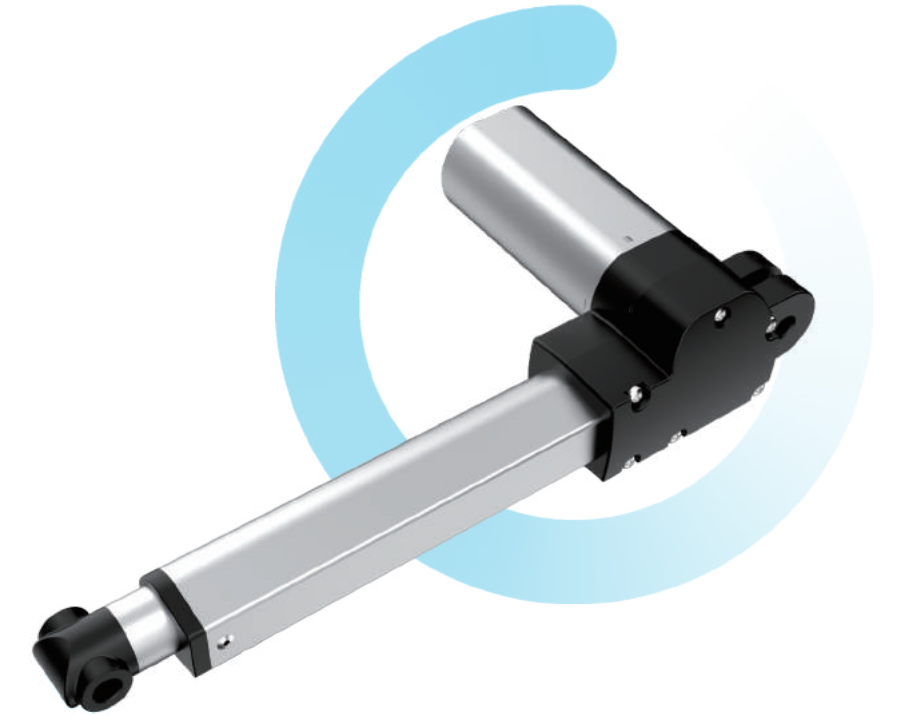

Technical specifications

Voltage (VDC)	Spindle pitch (mm)	Max. load in push (N)	Max. load in pull (N)	Mechanical self-lock (N)	Speed at no load /full load (mm/s)	Current at full load (A)
24	3	4500	2000	4500	6.4/4.0	≤5.0
	4	2500	2000	2500	8.3/6.6	≤3.5
29	3	4500	2000	4500	7.7/5.0	≤5.0
	4	2500	2000	2500	10.0/8.0	≤3.5

Remarks: It can achieve better self-locking ability with Bibus control box;
The above data is the standard value of the test data (inspection specification) at room temperature of 25°C.

JC35L

LINEAR ACTUATOR

Feature

- Max. load push(N): 4000
- Max. load pull(N): 3000
- Max. Speed(mm/s): 30
- Installation dimensions:
 General configuration:
 L=S+197
 (calculated according to the inner hole of the mounting plate)
 Special configuration (750N, double head, screw lead 16):
 L=S+200
 (calculated according to the outer hole of the mounting plate)
- Option:
 Hall sensor

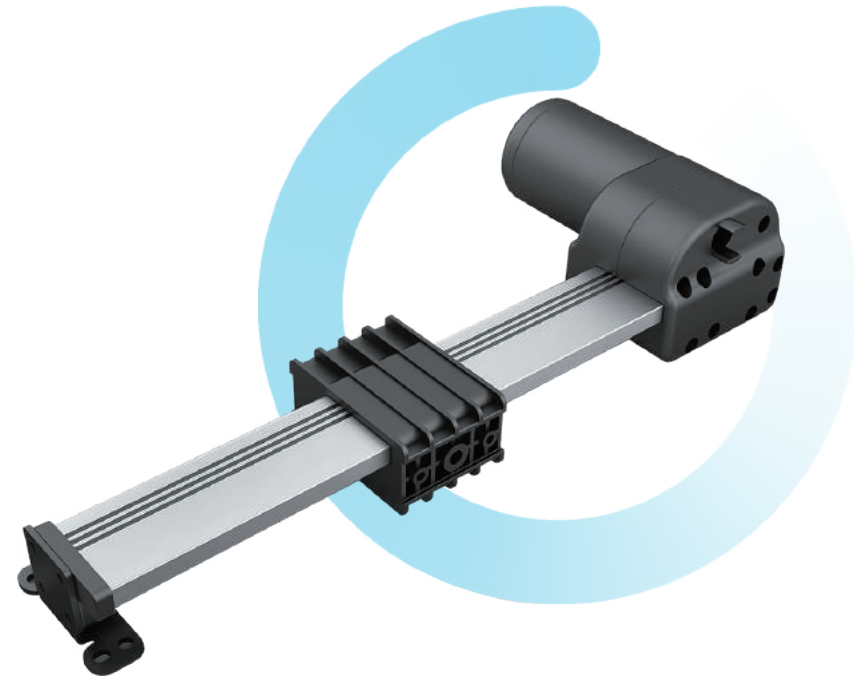

Technical specifications

Voltage (VDC)	Spindle pitch (mm)	Max. load in push (N)	Max. load in pull (N)	Mechanical self-lock (N)	Speed at no load /full load (mm/s)	Current at full load (A)
12	16	750	500	450	40/25	8±0.6
	12	1000	750	1000	30/23	7±0.6
	7.5	1500	1000	1500	20/13	8±0.6
	5	2000	1500	2000	13/8	8±0.6
	7.5	3000	2000	3000	10/7	8±0.6
	5	4000	3000	4000	6.5/3	9±0.6
24	12	450	200	450	22/18	1.3±0.3
	16	750	500	450	35/25	4±0.3
	12	750	500	750	33/25	3.8±0.3
	7.5	1000	750	1000	13/8	4±0.3
	12	1000	750	1000	25/21	4±0.3
	7.5	1500	1000	1500	21/13	4.5±0.3
	5	2000	1500	2000	13/9	4±0.3
	16	2000	1500	1000	26/16	5±0.3
	7.5	3000	2000	3000	10/6	4±0.3
29	5	4000	3000	4000	6.5/4	4±0.3
	12	450	200	450	26.5/21.5	1±0.3
	16	750	500	450	42/30	3.5±0.3
	12	750	500	750	40/30	3.5±0.3
	7.5	1000	750	1000	15.5/9.5	3.5±0.3
	12	1000	750	1000	30/25	3.5±0.3
	7.5	1500	1000	1500	25/15.5	4±0.3
	5	2000	1500	2000	15.5/10.5	4±0.3
	16	2000	1500	1000	31/19	4.5±0.3
	7.5	3000	2000	3000	12/7	3.5±0.3
	5	4000	3000	4000	8/5	3.5±0.3

Remarks: It can achieve better self-locking ability with Bibus control box;
 The above data is the standard value of the test data (inspection specification) at room temperature of 25°C.

JC35J1

LINEAR ACTUATOR

Feature

- Max load push(N): 2000
- Max load pull(N): 1500
- Max speed at full load(mm/s): 14.5
- Installation dimensions:
115≤L≤300(50≤S≤500)
- IP grade: /
- Option:
Hall sensor

Approval

- 1.CE:
EN60335-1:2012+A11+A13+A1+A14+A2
EN62233:2008
- 2.UL:UL1004-1,2nd Ed.,Issue Date: 2012-09-19,
Revision Date:2020-11-05,
- 3.UL1004-3,2nd Ed.,Issue Date: 2015-02-27,
Revision Date:2018-01-31

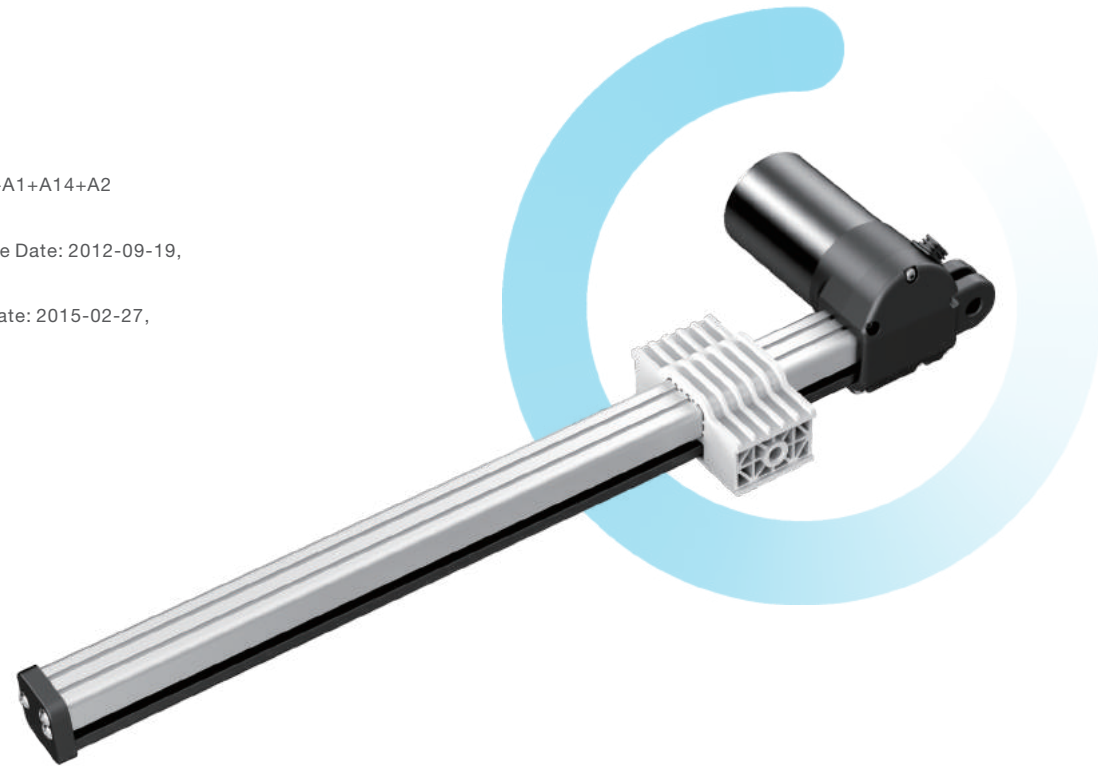

Technical specifications

Voltage (VDC)	Spindle pitch (mm)	Max load in push (N)	Max load in pull (N)	Mechanical self-lock (N)	Speed at no load /full load (mm/s)	Current at full load (A)
24	5	2000	1500	1500	16.7/12.0	≤4.5
29	5	2000	1500	1500	20.0/14.5	≤4.5

Remarks: It can achieve better self-locking ability with Bibus control box;
The above data is the standard value of the test data (inspection specification) at room temperature of 25°C.

JC35N6

LINEAR ACTUATOR

Feature

- Max. load push(N): 1200
- Max. load pull(N): 1200
- Max. speed(mm/s): 7.4
- Installation dimensions:
L=S+155(S≤300,Without hall)
L=S+170(S≤300,Hall sensor)
- IP grade: Max. IPX6
- Option:
Hall sensor

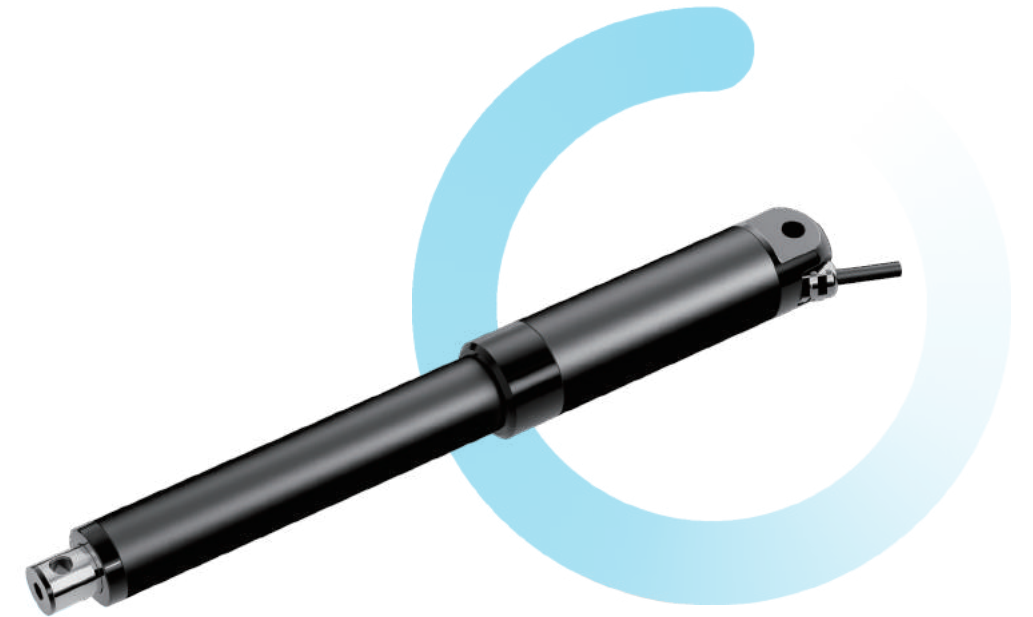

Technical specifications

Voltage (VDC)	Spindle pitch (mm)	Max load in push (N)	Max load in pull (N)	Mechanical self-lock (N)	Speed at no load /full load (mm/s)	Current at full load (A)
24	3	600	600	600	10.5/7.4	≤1.5
24	3	1200	1200	1200	7.0/4.5	≤1.5

Remarks: It can achieve better self-locking ability with Bibus control box;
The above data is the standard value of the test data (inspection specification) at room temperature of 25°C.

JC35N8

LINEAR ACTUATOR

Feature

- Max. load push(N): 2500
- Dynamic load pull(N): 900
- Max. speed(mm/s): 9.6
- Installation dimensions:
L=S+170(50≤S≤200,standard)
L=S+190(200<S≤300,standard,50≤S≤200,Only push no pull)
L=S+210(200<S≤300,Only push no pull)
- IP grade: Max. IPX6
- Option:
Only push no pull
Hall sensor
Safety nut

Approval

- 1.CE

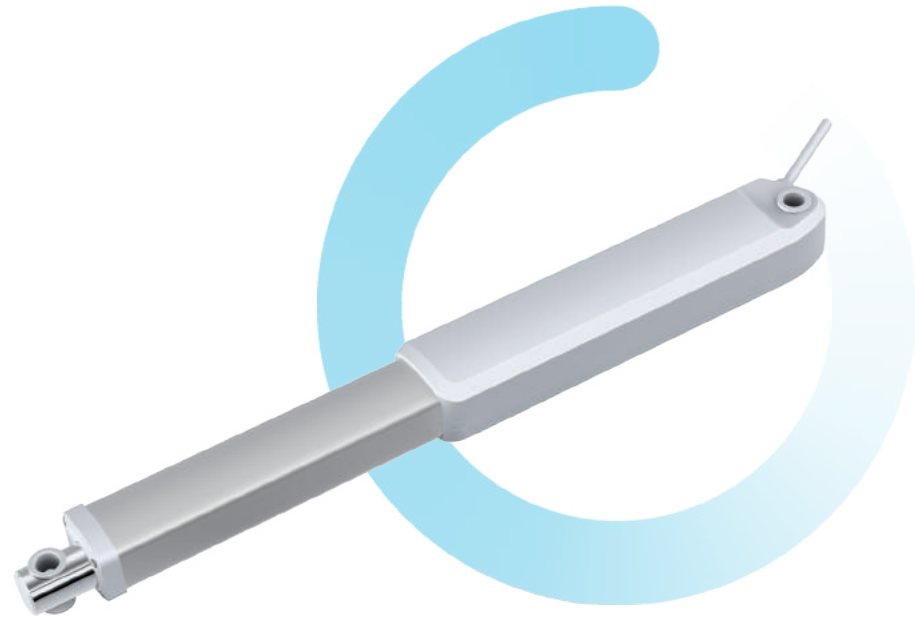

Technical specifications

Voltage (VDC)	Spindle pitch (mm)	Max. load in push (N)	Max. load in pull (N)	Mechanical self-lock (N)	Speed at no load /full load (mm/s)	Current at full load (A)
24	2.5	2500	900	1500	3.8/2.8	≤1.8
	3	2000	900	1500	4.6/3.4	≤1.8
	3	1500	900	1500	4.6/3.6	≤1.8
	5	800	800	800	7.3/6.3	≤1.8
	6	500	500	500	8.8/8.0	≤1.8
29	2.5	2500	900	1500	4.6/3.4	≤1.8
	3	2000	900	1500	5.5/4.1	≤1.8
	3	1500	900	1500	5.5/4.3	≤1.8
	5	800	800	800	8.8/7.6	≤1.8
	6	500	500	500	10.5/9.6	≤1.8

Remarks: It can achieve better self-locking ability with Bibus control box;
The above data is the standard value of the test data (inspection specification) at room temperature of 25°C.

JC35W1

LINEAR ACTUATOR

Feature

- Max. load push(N): 1000
- Max. load pull(N): 1000
- Max. speed(mm/s): 20
- Installation dimensions:
L=160(15≤S<50)
L=S+110(50≤S<400)
- IP grade: IPX4

Approval

- 1.ANSI/AAMI ES60601-1:2005/(R)2012 and A1:2012, C1:2009/(R)2012 and A2:2010/(R)2012
- 2.EN 60601-1:2006+A12:2014
- 3.IEC60601-1:2012

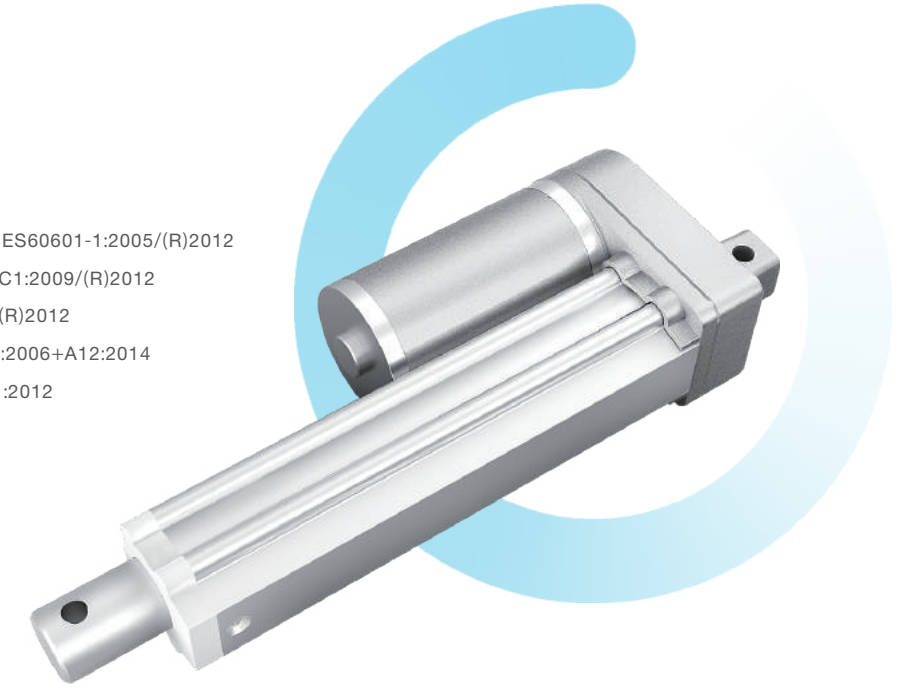

Technical specifications

Voltage (VDC)	Spindle pitch (mm)	Max load in push (N)	Max. load in pull (N)	Mechanical self-lock (N)	Speed at no load /full load (mm/s)	Current at full load (A)
12	2	1000	1000	1000	3.0/2.0	≤3.0
	3	750	750	750	5.0/3.0	≤3.0
	5	500	500	500	8.0/6.0	≤3.0
	10	250	250	250	16.0/10.0	≤3.0
	20	125	125	125	30.0/20.0	≤3.0
24	2	1000	1000	1000	3.3/2.0	≤1.5
	3	750	750	750	4.6/3.0	≤1.5
	5	500	500	500	7.5/6.0	≤1.5
	10	250	250	250	16.7/10.0	≤1.5
	4	125	125	125	25.0/20.0	≤1.5
29	2	1000	1000	1000	1.7/1.0	≤0.8
	10	250	250	250	8.3/6.0	≤0.8
	2	1000	1000	1000	4.0/2.4	≤1.5
	3	750	750	750	5.5/3.6	≤1.5
	5	500	500	500	9.0/7.2	≤1.5
29	10	250	250	250	20.0/12.0	≤1.5
	4	125	125	125	30.0/24.0	≤1.5
	2	1000	1000	1000	1.7/1.2	≤0.8
	10	250	250	250	10.0/7.2	≤0.8

Remarks: It can achieve better self-locking ability with Bibus control box;
The above data is the standard value of the test data (inspection specification) at room temperature of 25°C.

JC35W2

LINEAR ACTUATOR

Feature

- Max. load push(N): 3000
- Max. load pull(N): 3000
- Max. speed(mm/s):16
- Installation dimensions:
L=170(S≤50)
L=S+120(50≤S<400)
- IP grade: IPX4
- Option:
Hall sensor

Approval

- 1.ANSI/AAMI ES60601-1:2005/(R)2012 and A1:2012, C1:2009/(R)2012 and A2:2010/(R)2012
- 2.EN 60601-1:2006+A12:2014
- 3.IEC60601-1:2012

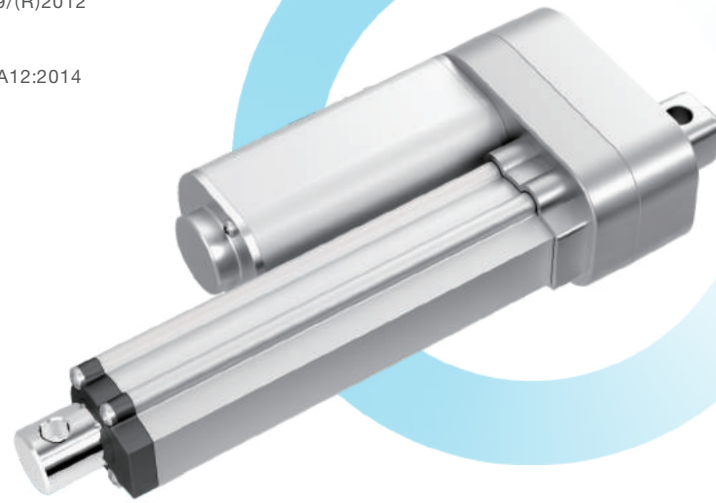

Technical specifications

Voltage (VDC)	Spindle pitch (mm)	Max. load in push (N)	Max. load in pull (N)	Mechanical self-lock (N)	Speed at no load /full load (mm/s)	Current at full load (A)
12	4	1000	1000	1000	8.0/5.5	≤6.0
	7.5	1000	1000	1000	13.0/8.5	≤6.0
	10	1000	1000	600	20.0/13.0	≤6.0
24	4	3000	3000	3000	7.5/5.0	≤5.0
	7.5	2000	2000	1500	14.0/9.0	≤5.0
	10	1000	1000	600	18.0/13.5	≤5.0
	4	3000	3000	3000	4.0/2.0	≤3.0
	7.5	2000	2000	1500	8.0/3.5	≤3.0
29	10	1000	1000	600	8.0/5.7	≤3.0
	20	1000	1000	500	16.5/10.0	≤3.0
	4	3000	3000	3000	9.0/6.0	≤5.0
	7.5	2000	2000	1500	17.0/11.0	≤5.0
	10	1000	1000	600	22.0/16.0	≤5.0
	4	3000	3000	3000	5.0/2.5	≤3.0
48	7.5	2000	2000	1500	10.0/4.0	≤3.0
	10	1000	1000	600	10.0/7.0	≤3.0
	20	1000	1000	500	20.0/12.0	≤3.0
	10	1000	1000	600	10.0/7.0	≤3.0

Remarks: It can achieve better self-locking ability with Bibus control box;
The above data is the standard value of the test data (inspection specification) at room temperature of 25°C.

JC35W2-2

LINEAR ACTUATOR

Feature

- Max. load push(N): 3000
- Max. load pull(N): 2000
- Max. speed(mm/s):16
- Installation dimensions:
L=170(20≤S<50)
L=S+120(50≤S<400)
- IP grade: Max. IPX6
- Option:
Hall sensor

Approval

- 1.ANSI/AAMI ES60601-1:2005/(R)2012 and A1:2012, C1:2009/(R)2012
- 2.EN 60335-1:2012+A11:2014+A13:2017+A1:2019+A14:2019+A2:2019



Technical specifications

Voltage (VDC)	Spindle pitch (mm)	Max. load in push (N)	Max. load in pull (N)	Mechanical self-lock (N)	Speed at no load /full load (mm/s)	Current at full load (A)
12	4	1000	/	1000	8.0/5.5	≤6.0
	7.5	1000	/	1000	13.0/8.5	≤6.0
	10	1000	/	600	20.0/13.5	≤6.0
24	4	3000	2000	3000	8.0/5.0	≤5.0
	7.5	2000	1000	1500	14.0/9.0	≤5.0
	10	1000	/	600	20.0/13.5	≤5.0
29	4	3000	2000	3000	9.0/7.5	≤5.0
	7.5	2000	1000	1500	17.0/10.8	≤5.0
	10	1000	/	600	22.0/16.0	≤5.0
48	4	3000	2000	3000	8.5/6.0	≤5.0
	7.5	2000	1000	1500	15.0/10.0	≤5.0
	10	1000	/	600	21.0/14.0	≤5.0

Remarks: It can achieve better self-locking ability with Bibus control box;
The above data is the standard value of the test data (inspection specification) at room temperature of 25°C.

JC35W5

LINEAR ACTUATOR

Feature

- Max. load push(N): 3000
- Max. load pull(N): 3000
- Max. speed(mm/s): 11
- Installation dimensions:
L=170(S≤50)
L=S+120 50≤S≤400
- IP grade: Max. IP68
- Option:
Hall sensor

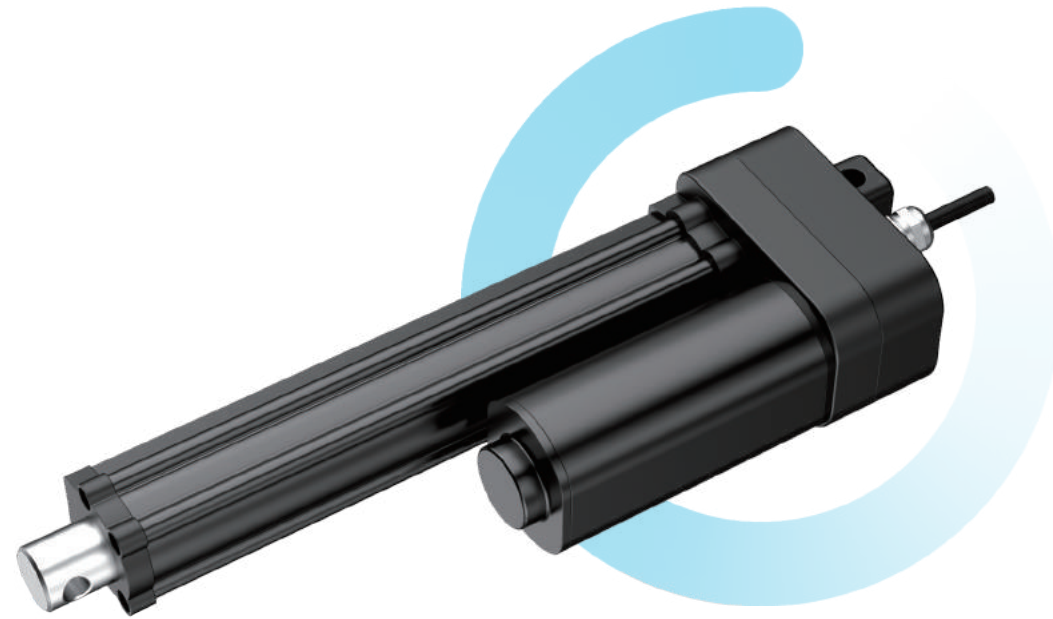

Technical specifications

Voltage (VDC)	Spindle pitch (mm)	Max load in push (N)	Max load in pull (N)	Mechanical self-lock (N)	Speed at no load /full load (mm/s)	Current at full load (A)
12	4	2000	2000	2000	7.0/4.5	≤6.0
	4	3000	3000	3000	7.4/4.8	≤5.0
24	7.5	2000	2000	2000	13.2/8.3	≤5.0
	10	1000	1000	1000	18.2/11.0	≤4.0

Remarks: It can achieve better self-locking ability with Bibus control box;
The above data is the standard value of the test data (inspection specification) at room temperature of 25°C.

JC35W8

LINEAR ACTUATOR

Feature

- Max. load push(N): 1000
- Max. load pull(N): 1000
- Max. speed(mm/s): 71
- Installation dimensions:
Common and with dual hall sensor
L=S+105(25≤S≤610)
L=S+120(610<S≤765)
L=S+140(765<S≤1020)
With potentiometer
L=S+140(25≤S≤610)
L=S+155(610<S≤765)
L=S+175(765<S≤1020)
- IP grade: Max. IPX6
- Option:
Hall sensor
With potentiometer

Approval

- 1.EN 60335-1:2012+A11:2014+A13:2017+A1 : 2019+A14:2019+A2:2019
- 2.ANSI/AAMI ES60601-1:A1:2012, C1:2009/(R)2012 and A2:2010/(R)2012

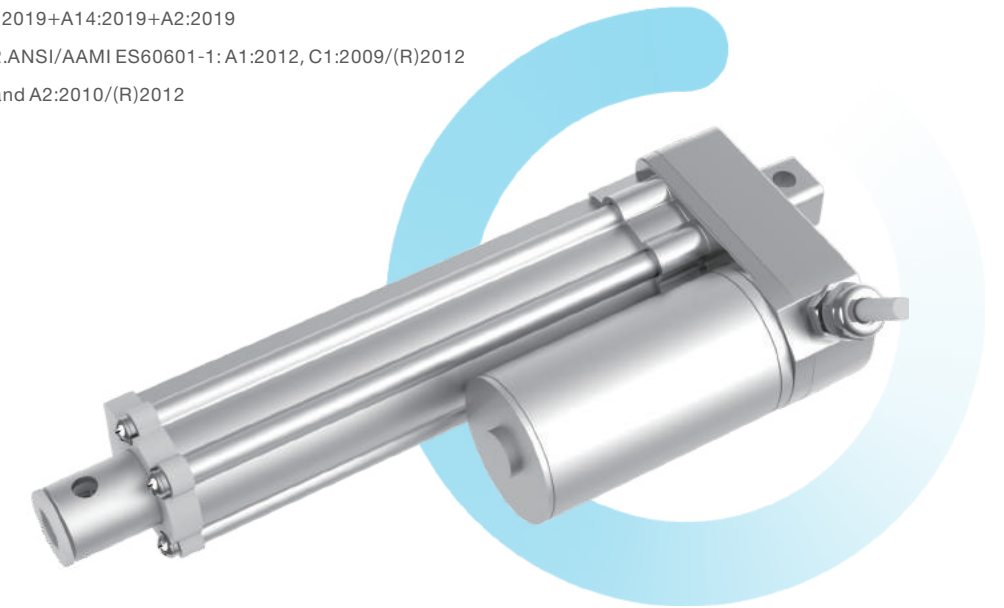

Technical specifications

Voltage (VDC)	Spindle pitch (mm)	Max. load in push (N)	Max. load in pull (N)	Mechanical self-lock (N)	Speed at no load /full load (mm/s)	Current at full load (A)
12	2	1000	1000	1000	7.0/5.0	≤3.5
	3	750	750	750	10.0/7.5	≤3.5
	5	500	500	500	24.0/17.0	≤3.5
	7.5	250	250	250	35.0/26.0	≤3.5
	10	125	125	125	50.0/34.5	≤3.5
	20	70	70	70	90.0/67.5	≤3.5
24	2	1000	1000	1000	7.0/5.2	≤2.0
	3	750	750	750	10.0/8.0	≤2.0
	5	500	500	500	24.0/18.0	≤2.0
	7.5	250	250	250	35.0/27.0	≤2.0
	10	125	125	125	50.0/36.0	≤2.0
	20	70	70	70	90.0/71.0	≤2.0

Remarks: It can achieve better self-locking ability with Bibus control box;
The above data is the standard value of the test data (inspection specification) at room temperature of 25°C.

JC35S11

DUAL MOTOR

Feature

- Max. load push(N): 2*4500
- Max. speed(mm/s): 3.5
- Voltage: 100VAC~240VAC(Input)
29VDC(Output)
- Installation dimensions:
L=581mm
- Stroke length:
Backrest stroke: Max.87mm
Legrest stroke: Max.69mm
- IP grade: /

Approval

- 1.EN60335-1:2021+A11+A13+A1+A2+A14
- 2.EN62233:2008
- 3.ENISO.12100:2010

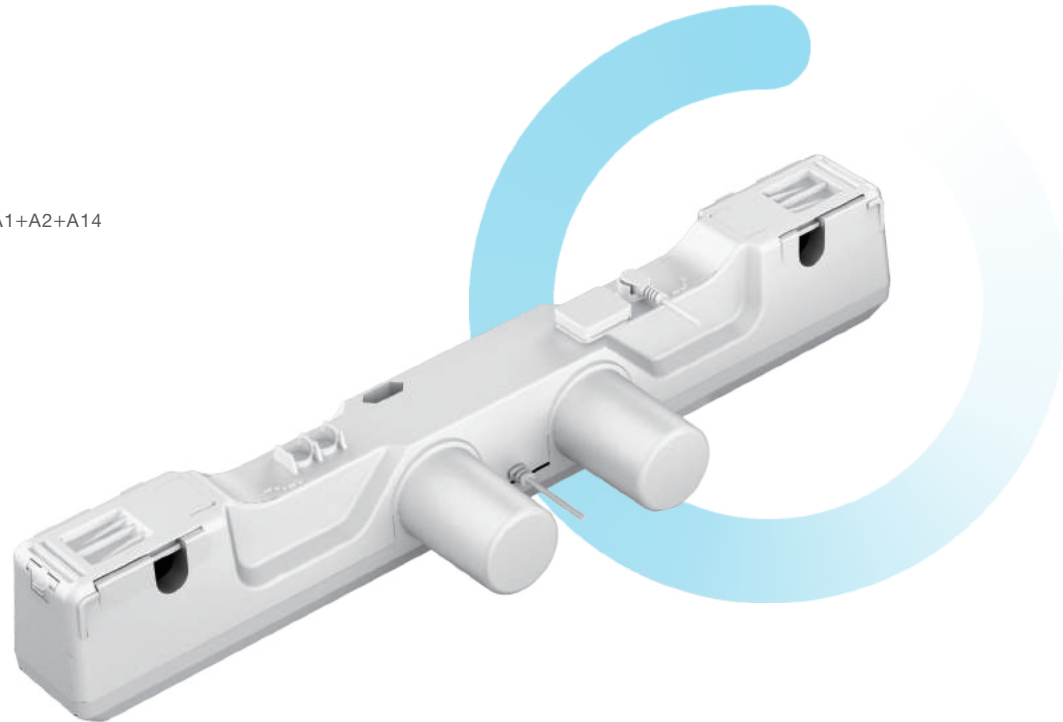

Technical specifications

Voltage (VDC)	Spindle pitch (mm)	Max. load in push (N)	Mechanical self-lock (N)	Speed at no load /full load (mm/s)	Current at full load (A)
29	3	2*4500	2*4500	5.0/3.5	3.0

Remarks: It can achieve better self-locking ability with Bibus control box;
The above data is the standard value of the test data (inspection specification) at room temperature of 25°C.

JC35EA-3C

LIFTING COLUMN

Feature

- Max. load in push &self-locking(N): 2000
- Max. static bending moment(Nm): 500
- Max. dynamic bending moment(Nm): 250
- Max. speed(mm/s): 16
Installation dimensions: L=S/2+150
- IP grade: Max. IPX6
- Option:
With hall sensor(Apply for synchronize or memory function)

Approval

- 1.CE,CB,UL



Technical specifications

Voltage (VDC)	Max. load in push (N)	Self-lock (N)	Max. bending moment (Static)(NM)	Max. bending moment (Dynamic)(NM)	Speed at no load /full load (mm/s)	Current at full load (A)
29	2000	2000	500	250	19.0/16.0	5.0

Remarks: It can achieve better self-locking ability with Bibus control box;
The above data is the standard value of the test data (inspection specification) at room temperature of 25°C.

JC35EA-3A

LIFTING COLUMN

Feature

- Max. load in push & self-locking(N): 2000
- Max. static bending moment(Nm): 500
- Max. dynamic bending moment(Nm): 250
- Max. speed(mm/s): 12
- Installation dimensions: L=S/2+150
- IP grade: IPX4
- Option:
With hall sensor(Apply for synchronize or memory function)

Approval

1.CE,CB,UL



Technical specifications

Voltage (VDC)	Max. load in push (N)	Self-lock (N)	Max. bending moment (Static)(NM)	Max. bending moment (Dynamic)(NM)	Speed at no load /full load (mm/s)	Current at full load (A)
24	2000	2000	500	250	13.0/12.0	5.0

Remarks: It can achieve better self-locking ability with Bibus control box;
The above data is the standard value of the test data (inspection specification) at room temperature of 25°C.

JC35EG

LIFTING COLUMN

Feature

- Max. load in push & self-locking(N): 2000
- Max. static bending moment(Nm): 400
- Max. dynamic bending moment(Nm): 200
- Max. speed: 10
- Installation dimensions: L=S/2+200
- IP grade: IPX4
- Option:
With hall sensor(Apply for synchronize or memory function)
With aluminium holder for mounting

Approval

1.EN 60601-1:2006+A12:2014
2.IEC60601-1:2012



Technical specifications

Voltage (VDC)	Spindle pitch (mm)	Max. load in push (N)	Self-lock (N)	Max. bending moment (Static)(NM)	Max. bending moment (Dynamic)(NM)	Speed at no load /full load (mm/s)	Current at full load (A)
29	6	2000	2000	400	200	15.0/10.0	6.5

Remarks: It can achieve better self-locking ability with Bibus control box;
The above data is the standard value of the test data (inspection specification) at room temperature of 25°C.

JC35EM2

LIFTING COLUMN

Feature

- Max. load in push & self-locking(N): 6000
- Max. static bending moment(Nm): 1000
- Max. dynamic bending moment(Nm): 500
- Max. speed(mm/s): 25
- Installation dimensions:
L=S+200(S<400)
L=S+220(S≥400)
- IP grade: IPX4
- Option:
With hall sensor(Apply for synchronize or memory function)

Approval

1.EN 60601-1:2006+A12:2014



Technical specifications

Voltage (VDC)	Spindle pitch (mm)	Max. load in push (N)	Self-lock (N)	Max. bending moment (Static)(NM)	Max. bending moment (Dynamic)(NM)	Speed at no load /full load (mm/s)	Current at full load (A)
24	4	6000	6000	900	500	5.0/3.0	6.0
	5	4000	4000	900	500	6.0/4.0	5.0
	7.5	3000	3000	900	500	9.0/6.0	6.0
	5	2000	2000	900	500	13.0/9.0	6.0
	16	1500	1500	500	250	20.0/13.0	6.0
	20	1000	1000	500	250	25.0/20.0	5.0
	16	750	750	500	250	42.0/25.0	4.5

Remarks: It can achieve better self-locking ability with Bibus control box;
The above data is the standard value of the test data (inspection specification) at room temperature of 25°C.

JC35EM3

LIFTING COLUMN

Feature

- Max. load in push & self-locking(N): 2000
- Max. static bending moment(Nm): 900
- Max. dynamic bending moment(Nm): 500
- Max. speed(mm/s): 10
- Installation dimensions:
L=S/2+150(S≤400)
L=S/2+200(S>400)
- IP grade: IPX4
- Option:
With hall sensor(Apply for synchronize or memory function)

Approval

1.EN 60601-1:2006+A12:2014

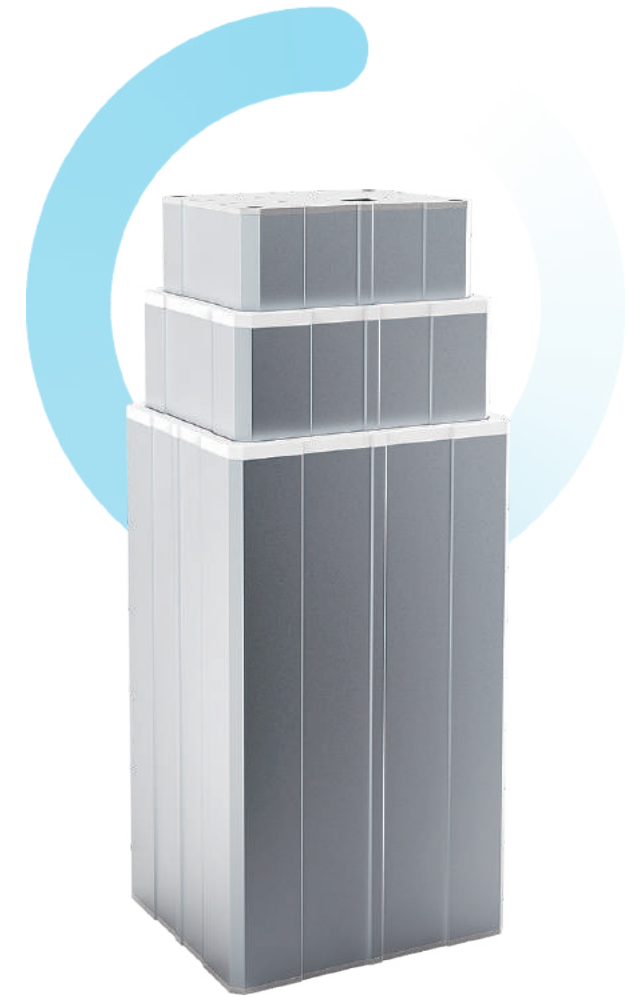

Technical specifications

Voltage (VDC)	Spindle pitch (mm)	Max. load in push (N)	Self-lock (N)	Max. bending moment (Static)(NM)	Max. bending moment (Dynamic)(NM)	Speed at no load /full load (mm/s)	Current at full load (A)
24	6	2000	2000	900	500	12.0/10.0	5.0

Remarks: It can achieve better self-locking ability with Bibus control box;
The above data is the standard value of the test data (inspection specification) at room temperature of 25°C.

JC35EN2

LIFTING COLUMN

Feature

- Max. load in push & self-locking(N): 6000
- Max. static bending moment(Nm): 900
- Max. dynamic bending moment(Nm): 500
- Max. speed(mm/s): 25
- Installation dimensions:
L=S+200(S<400)
L=S+220(S ≥ 400)
- IP grade: IPX4
- Option:
With hall sensor(Apply for synchronize or memory function)

Approval

1.EN 60601-1:2006+A12:2014



Technical specifications

Voltage (VDC)	Spindle pitch (mm)	Max. load in push (N)	Self-lock (N)	Max. bending moment (Static)(NM)	Max. bending moment (Dynamic)(NM)	Speed at no load /full load (mm/s)	Current at full load (A)
24	4	6000	6000	900	500	5.0/3.0	6.0
	5	4000	4000	900	500	6.0/4.0	5.0
	7.5	3000	3000	900	500	9.0/6.0	6.0
	5	2000	2000	900	500	13.0/9.0	6.0
	16	1500	1500	500	250	20.0/13.0	6.0
	20	1000	1000	500	250	25.0/20.0	5.0
	16	750	750	500	250	42.0/25.0	4.5

Remarks: It can achieve better self-locking ability with Bibus control box;
The above data is the standard value of the test data (inspection specification) at room temperature of 25°C.

JC35EN-3A

LIFTING COLUMN

Feature

- Max. load in push & self-locking(N): 6000
- Max. static bending moment(Nm): 2000
- Max. dynamic bending moment(Nm): 1750
- Max. speed(mm/s): 11.5
- Installation dimensions:
Lmin= S/2+150 (2000N)
Lmin= S/2+200 (4000N)
Lmin= S/2+250 (6000N)
- IP grade: IPX4
- Option:
With hall sensor(Apply for multi-column synchronous lifting)

Approval

1.EN 60601-1:2006+A12:2014

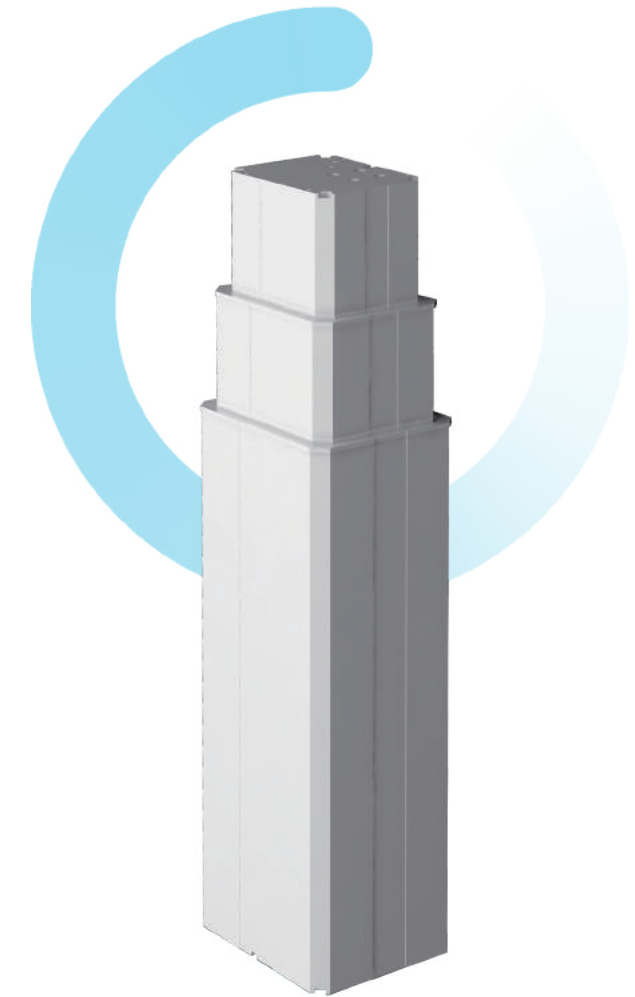

Technical specifications

Voltage (VDC)	Spindle pitch (mm)	Max. load in push (N)	Self-lock (N)	Max. bending moment (Static)(NM)	Max. bending moment (Dynamic)(NM)	Speed at no load /full load (mm/s)	Current at full load (A)
24	5	6000	6000	2000	1750	6.5/5.5	7.0
	7.5	4000	4000	1500	1250	9.5/8.5	6.0
	10	2000	2000	1000	750	13.0/11.5	5.0

Remarks: It can achieve better self-locking ability with Bibus control box;
The above data is the standard value of the test data (inspection specification) at room temperature of 25°C.

JC35ESN-2

LIFTING COLUMN

Feature

- Max. load in push & self-locking(N): 1000
- Max. speed(mm/s): 11.0
- Installation dimensions:
L=S+145 (100<S≤450)
- IP grade: IP43
- Option:
With hall sensor(Apply for synchronize or memory function)

Approval

- 1.ANSI/AAMI ES60601-1:2005/(R)2012
and A1:2012, C1:2009/(R)2012
and A2:2010/(R)2012
- 2.EN 60601-1:2006+A12:2014



Technical specifications

Voltage (VDC)	Spindle pitch (mm)	Max. load in push (N)	Self-lock (N)	Stroke (mm)	Speed at no load /full load (mm/s)	Current at full load (A)
24	7.5	1000	1000	100-450	14.0/11.0	≤4.0

Remarks: It can achieve better self-locking ability with Bibus control box;
The above data is the standard value of the test data (inspection specification) at room temperature of 25°C.

JC35ES2

LIFTING COLUMN

Feature

- Max. load in push & self-locking(N): 6000
- Max. speed(mm/s): 21
- Installation dimensions:
L=S+150(S<400mm)
L=S+170(S≥400mm)
- IP grade: IP43
- Option:
With hall sensor(Apply for synchronize or memory function)

Approval

CE, UL



Technical specifications

Voltage (VDC)	Spindle pitch (mm)	Max. load in push (N)	Electronic self-locking (N)	Mechanical self-locking (N)	Speed at no load /full load (mm/s)	Current at full load (A)
24	4	1000	≥1000	≥800	30/21	≤4.5
	2.5	2000	≥3000	≥3000	13/9	≤4.5
	2.5	3000	≥3000	≥3000	9/6	≤4.5
	2.5	4000	≥4000	≥4000	7/4.5	≤4.5
	4	6000	≥6000	≥6000	5.5/3.5	≤4.5
12	4	1000	≥1000	≥800	30/20	≤9
	2.5	2000	≥2000	≥2000	13/8	≤9
	2.5	4000	≥4000	≥4000	8/4.5	≤10.1

Remarks: It can achieve better self-locking ability with Bibus control box;
The above data is the standard value of the test data (inspection specification) at room temperature of 25°C.

JC35ES3

LIFTING COLUMN

Feature

- Max. load in push & self-locking(N): 2000
- Max. speed(mm/s): 18
- Installation dimensions:
L=S/2+200
- IP grade: IP43
- Option:
With hall sensor(Apply for synchronize or memory function)

Approval

CE, UL



Technical specifications

Voltage (VDC)	Spindle pitch (mm)	Max. load in push (N)	Electronic self-locking (N)	Mechanical self-locking (N)	Speed at no load /full load (mm/s)	Current at full load (A)
24	6/2+6/3	1000	≥1000	≥1000	25/18	≤6.5
	6/2+6/3	2000	≥2000	≥2000	15/10	≤6.5

Remarks: It can achieve better self-locking ability with Bibus control box;
The above data is the standard value of the test data (inspection specification) at room temperature of 25°C.

Controller



JCB35Q

- Outputs for actuator: 1-4
- Max output voltage(VDC):29
- Power supply:SMPS
- IP grade: Max. IPX6



JCB35Q3

- Outputs for actuator: 1-3
- IP grade:IPX4



JCB35T

- Outputs for actuator: 1-4
- Max output voltage(VDC):29
- Power supply:SMPS
- Connect separated battery
- IP grade: Max. IPX6



JCB35T1

- Outputs for actuator: 1-4
- Max output voltage(VDC):36
- Power supply:SMPS
- Connect separated battery
- IP grade: Max. IPX6



JCB35T2

- Outputs for actuator: 1-4
- Max output voltage(VDC):36
- Power supply:SMPS
- Connect separated battery
- IP grade: Max. IPX6



JCB35T3

- Outputs for actuator: 1-4
- Max output voltage(VDC):36
- Built-in dry battery:emergency drop function
- Connected to adaptor
- IP grade: Max. IPX6



JCB35T6

- Outputs for actuator: 1-5
- Power supply:SMPS
- IP grade: Max. IPX6



JCB35R

- Outputs for actuator: 1-6
- Max output voltage(VDC):29
- Power supply:SMPS
- Connect separated battery
- IP grade: Max. IPX6



JCB35R1

- Outputs for actuator: 1-6
- Connected to adaptor
- IP grade: Max. IPX6

Controller



JCB35K2-A

- Outputs for actuator:1-2
- Output voltage(VDC):25.9
- Rated capacity(AH):2.2/4.4
- Type of battery: Li-ion
- With LCD display
- IP grade:IPX4

JCB35K2-B

- Outputs for actuator:1-2
- Output voltage(VDC):25.9
- Rated capacity(AH):2.2/4.4
- Type of battery:Li-ion
- IP grade:IPX4

JCB35K3

- Outputs for actuator:1-3
- Output voltage(VDC):25.9
- Rated capacity(AH):3.2/5.2
- Type of battery: Li-ion
- With 2.0 inches TFT color screen
- IP grade: Max. IPX6

Operator



JCHN35H1

- Intuitive control up to 2 physical buttons
- 10.1 inches IPS capacitive screen
- Display related data and bed status
- IP grade:IP20

JCHN35H2

- Intuitive control up to 2 physical buttons
- With electronic lock
- 7 inches IPS capacitive screen
- Display related data and bed status
- IP grade: Max. IPX6

JCHN35H3

- Embedded nurse control
- 7 inch touch capacitive screen
- Display related data and bed status
- IP grade:IPX4

Operator



JCHN35E1

- Intuitive control up to 26 buttons
- IP grade: Max. IPX6

JCHN35H

- Intuitive control up to 30 buttons
- With 3.5 inches TFT color screen
- Date display
- IP grade: Max. IPX6

JCH35A6

- Max available buttons:12
- With touch sensitive function
- Electronic lock function optional
- Background light
- IP grade: Max. IPX6



JCH35A7

- Max available buttons:14
- Background light
- IP grade: Max. IPX6

JCH35A9

- Max available buttons:10
- With 2.0 inches TFT color screen
- With electronic lock
- IP grade: Max. IPX6

JCH35A10

- Max available buttons:6
- Connect with JCB35K3
- IP grade: Max. IPX6



JCH35A11

- Max available buttons:6
- Magnetic fixing method
- Connect with JCB35K3
- IP grade: Max. IPX6

JCH35A12

- Max available buttons:10
- With 2.0 inches TFT color screen
- Cable replaceable
- IP grade: Max. IPX6

JCH35A15

- Max available buttons:10
- Background light
- With mechanical lock
- IP grade: Max. IPX6

Operator



JCH35A16

- Max available buttons:10
- Background light
- IP grade: Max. IPX6



JCH35A18

- Max available buttons:10
- Cable replaceable
- IP grade: Max. IPX6



JCH35A19

- Max available buttons:8
- IP grade: Max. IPX6



JCH35V2

- Max available buttons:8
- IP grade:IPX4



JCH35V3

- Max available buttons:4
- IP grade:IPX4



JCHR35F

- Max available buttons:6
- 2.4G Wireless
- IP grade:IP20



JCHR35G

- Max available buttons:10
- Bluetooth
- IP grade: Max. IPX6



JCHQ35

- Max available buttons:6
- IP grade:IP20



JCH35A8

- Max available buttons:29
- IP grade:IPX6

Operator



JCF35V1

- Max number of splicing:2
- IP grade: Max. IPX6



JCF35V2

- Max number of splicing:3
- 2.4G Wireless
- IP grade: Max. IPX6



JCF35V3

- Max number of splicing:5
- IP grade: Max. IPX6



JCFN35

- Max number of splicing:3
- IP grade: Max. IPX6

Accessories

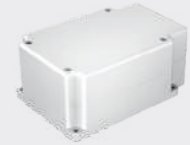

JCP35PA-B-1

- Battery box
- Rated capacity(AH):1.3
- Type of battery:Lead-Acid
- IP grade:IPX4



JCP35PA-B1

- Battery box
- Rated capacity(AH):1.3/2.8
- Type of battery: Lead-Acid
- IP grade: Max. IPX6



JCP35PA-B-2

- Battery box
- Rated capacity(AH):2.2
- Type of battery: Li-ion
- IP grade: Max. IPX6



JCP35PA-B2

- Battery box
- Rated capacity(AH):2.6
- Type of battery: Li-ion
- IP grade: Max. IPX6



JCP35J01

- With electrical controller
- With 3.5 inches TFT color screen

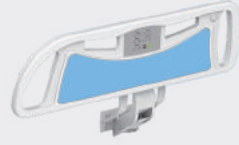

JCP35H02

- With electrical controller



JCP35H03

- With electrical controller



JCP35H05

- With electrical controller



JCP35H09

- With electrical controller
- IP grade:IPX4

Accessories



JCP35Q

- Safety switch
- Emergency stop button
- Cut off DC power
- IP grade: Max. IPX6



JCP35C

- Connection box
- Number of the hand/foot controls:1-5
- IP grade: Max. IPX6



JCP35Q1

- Safety switch
- Ring-pulling emergency stop switch
- Cut off AC power
- IP grade: Max. IPX6



JCP35C3

- Connection box
- Can-bus
- IP grade: Max. IPX6W



JCP35C5

- Connection box
- Can-bus
- IP grade: Max. IPX6W



JCP35PA-Q1

- Medical power adapter
- Output voltage(VDC):29
- Standby power consumption(W): <0.15
- Rated power:29V/3A
- IP grade: Max. IPX6



JCP35PA-03

- Medical power adapter
- Output voltage(VDC):36
- Standby power consumption(W):<0.5
- Rated power:36V/2A
- Plug replaceable
- IP grade: Max. IPX6



JCP35E1-LED

- Night light mounted under the bed
- IP grade: Max. IPX6

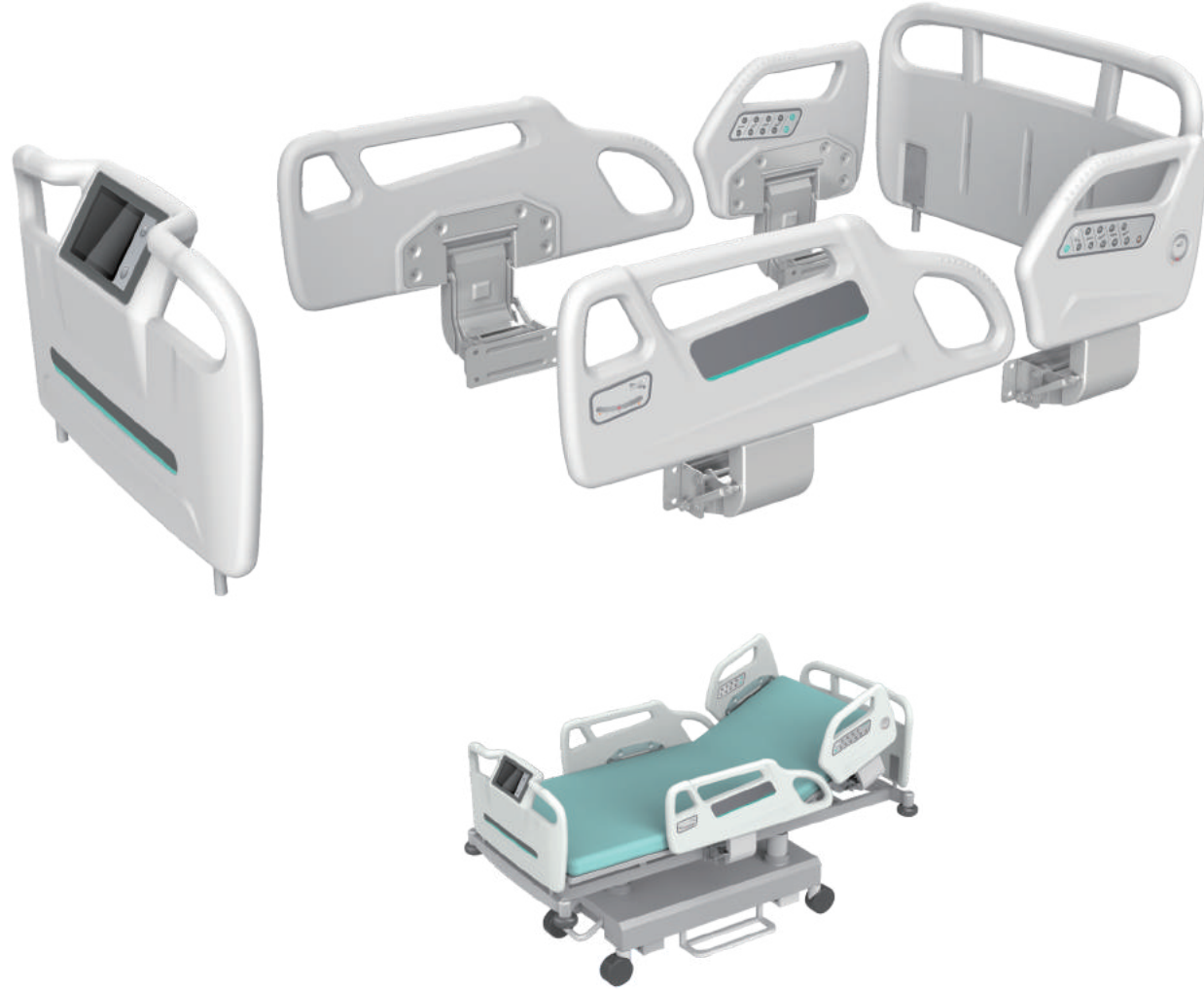

JCP35H09

Newly upgraded guardrail

1. Brand new guardrail, novel and unique in shape, and has appearance patent
2. Comply with (EN60601-2-52) standard to ensure that customers pass various tests
3. The footboard of the bed can be adapted to a variety of operators (3.5 inches, 7 inches)



7 inches



3.5 inches

Genel Merkez

Switzerland
BIBUS AG
Allmendstrasse 26
8320 FEHRALTORF
Tel. +41 44 877 50 11
Fax +41 44 877 50 19
E-Mail info.bag@bibus.ch
www.bibus.ch

Switzerland
BIBUS HYDRAULIK AG
Allmendstrasse 26
8320 FEHRALTORF
Tel. +41 44 877 52 11
Fax +41 44 877 52 19
E-Mail bibushydraulik@bibus.ch
www.bibushydraulik.ch

Dünya'da BIBUS

Austria
BIBUS Austria Ges.m.b.H.
Eduard Klinger-Straße 12
A-3423 St. Andrä-Wördern
Tel. +43 2242 333 88
Fax +43 2242 333 88 10
E-mail info@bibus.at
www.bibus.at

Latvia
BIBUS Baltics SIA
Kleistu iela 24
LV-1067 RIGA
Tel. +371 6763 05 01
Fax +371 6763 05 01
E-mail info@bibusbaltics.eu
www.bibusbaltics.eu

Belarus
BIBUS cooo
8th Per. Ilyicha 13a, office 2.1
246013 GOMEL
Tel. +375 232 29 31 39
Fax +375 232 29 72 05
E-mail info@bibus.by
www.bibus.by

Bosnia
BIBUS doo
Karadordeva bb BA 76311
Dvorovi-Bijeljina Hercegovina
Tel. +387 55 423 444
Fax +387 55 423 444
E-mail info@bibus.ba
www.bibus.ba

Slovenia
INOTEH d.o.o.
K železnici 7
SI-2345 Bistrica ob Dravi
Tel. +386 2 665 11 31
Fax +386 2 665 20 81
E-mail info@inoteh.si
www.inoteh.si

China
BIBUS Shanghai Mec. Ltd.
2nd Floor, Block 9, No. 188
Shanfeng Road 201508
Tel. +86 21 5803 9270
Fax +86 21 6729 8667
E-mail info@bibuschina.cn
www.bibuschina.cn

Croatia
BIBUS Zagreb d.o.o.
Anina 91
HR-10000 ZAGREB
Tel. +385 1 3818 004
Fax +385 1 3818 005
E-mail bibus@bibus.hr
www.bibus.hr

Czech Republic
BIBUS s.r.o.
Vědeňská 125
619 00 BRNO
Tel. +420 547 125 300
Fax +420 547 125 310
E-mail bibus@bibus.cz
www.bibus.cz

Denmark
BIBUS Sindby A/S
Edisonvej 11
7100 Vejle
Tel. +45 75 88 21 22
Fax +45 75 88 21 21
E-mail bibus@bibus.dk
www.bibus-sindby.dk

France
BIBUS France S.A.S.
ZA du Chapotin Sud
233, rue des Frères Voisin
69970 CHAPONNAY
Tel. +33 4 78 96 80 00
Fax +33 4 78 96 80 01
E-mail contact@bibusfrance.fr
www.bibusfrance.fr

India
BIBUS India Pvt Ltd.
Yellapura Village, Kasaba Hobli,
Near KSSIDC Industrial Area,
Doddaballapura Taluk No.102/25,
1st Floor, Bangalore - 561203.
Tel. +91-953 802 78 82
E-mail info@bibus.in
www.bibus.in

Germany
SAUER BIBUS GmbH
Lise-Meitner-Ring 13
89231 NEU-ULM
Tel. +49 731 1896 0
Fax +49 731 1896 199
E-mail info@sauerbibus.de
www.sauerbibus.de

Germany
WESER-PUMPEN GmbH
Güterstrasse 10
27777 Ganderkesee
Tel. +49 4222 947 510 0
Fax +49 4222 947 510 10
E-mail info@weser-pumpen.de
www.weser-pumpen.de

Netherlands
BIBUS Romicon B.V.
Vlijtweg 10A
8191 JP Wapenveld
Tel. +31 38 447 91 81
E-mail info@bibusromicon.nl
www.bibusromicon.nl

Hungary
BIBUS Kft.
Almáskert út 9.
2220 VECSÉS
Tel. +36 29 557 764
Fax +36 29 557 777
E-mail info@bibus.hu
www.bibus.hu

Italy
BIBUS Italia Srl
Via Robert Fulton, 27
San Giovanni in Persiceto (BO)
40017 C.F. e P.IVA n. 03248661203
Tel. +39 051 893958
Fax +39 051 780081
E-mail info@bibus.it
www.bibus.it

Bulgaria
BIBUS Bulgaria Ltd.
2 Blvd. Prof. Tzvetan Lazarov,
Floor 2, 1574 SOFIA
Tel. +359 2 971 98 08
Fax +359 2 927 32 64
E-mail info@bibus.bg
www.bibus.bg

Malaysia
BIBUS Malaysia Sdn. Bhd.
7, Jalan Kartunis, U1/47,
Glenmarie Temasya Industrial Park
40150, Shah Alam, Selangor
Tel. +60 3 5569 70 77
Fax +60 3 5569 70 66
Email info@bibus.my
www.bibus.my

Great Britain
BIBUS (UK) Ltd
Unit 20-21 Soho Mills
WOOBURN GREEN
Bucks HP10 0PF
Tel. +44 1628 533 300
Fax +44 1628 533 377
Email info@bibus.uk
www.bibus.uk

Poland
BIBUS Menos Sp. z o.o.
ul. Spadochroniarzy 18
80-298 Gdańsk
Tel. +48 58 660 95 70
Fax +48 58 661 71 32
E-mail info@bibusmenos.pl
www.bibusmenos.pl

Portugal
BIBUS Portugal, Lda
Centro Empresarial AAA
Rua Ponte da Pedra, 240 - C4
4470-108 Gueifães-Maia
Tel. +351 22 906 50 50
Fax +351 22 906 50 41
E-mail info@bibus.pt
www.bibus.pt

Romania
BIBUS Ses Srl
134/1 Calea Lugojului
307200 GHIRODA, TIMIS
Tel. +40 256 200 500
Fax +40 356 446 660
E-mail office@bibus.ro
www.bibus.ro

Russia
BIBUS o.o.o.
Zemskaya street 94
198205 ST. PETERSBURG
Tel. +7 800 100 14 52
Fax +7 812 309 41 51
E-mail info@bibus.ru
www.bibus.ru

Slovakia
BIBUS SK s.r.o.
Trnavská 31
949 01 NITRA
Tel. +421 37 777 79 11
Fax +421 37 777 79 19
E-mail sale@bibus.sk
www.bibus.sk

Germany
BIBUS GmbH
Max-Eyth-Straße 41/1
89231 NEU-ULM
Tel. +49 731 20 76 90
Fax +49 731 20 76 96 20
E-mail info@bibus.de
www.bibus.de

Spain
BIBUS Spain, S.L.
Rua do Arroncal, Vial C - Nave 4A
Parque Empresarial Porto do Molle
36350 NIGRAN (Pontevedra)
Tel. +34 986 24 72 86
Fax +34 986 20 92 47
E-mail info@bibus.es
www.bibus.es

Thailand
BIBUS Thailand
181/68 Soi Nuanchan 32
Nuanchan Buengkhum District
Bangkok 10230
Tel. +66 90 894 98 67
Fax +66 2 054 65 76
Email info@bibus.co.th
www.bibus.co.th

Switzerland
BIBUS Hydraulik AG
Allmendstrasse 26
8320 FEHRALTORF
Tel. +41 44 877 52 11
Fax +41 44 877 52 19
E-Mail bibushydraulik@bibus.ch
www.bibushydraulik.ch

Turkey
BIBUS Endüstriyel A.Ş.
İkitelli OSB Bedrettin Dalan Bulvarı
Vip Plaza Kat:2 No:43-44, 34490
Bağcılar / İSTANBUL
Tel. 444 20 38
Fax +90 212 249 88 34
E-mail info@bibus.com.tr
www.bibus.com.tr

Turkey
BIBUS Hidrotos A.Ş.
Ostim OSB 1233. Cd. No:149
Yenimahalle/Ankara
Tel. +90 312 354 29 27
Fax +90 312 354 91 61
E-mail info@bibushidrotos.com.tr
www.bibushidrotos.com.tr

Ukraine
BIBUS Ukraine TOV
Soborna st., 118 the village of
Sofiyivska Borschagivka
Kiev region 08147
Tel. +380 44 545 44 04
Fax +380 44 545 54 83
E-mail info@bibus.ua
www.bibus.ua

Vietnam
BIBUS Vietnam Technology Co., Ltd.
No. 10, Lot K, Hoang Quoc Viet street
Phu My Ward, District 7, Ho Chi Minh City,
Tel. +84 28 3785 0627
Fax +84 8 378 506 28
E-mail info@bibus.vn
www.bibus.vn