

Gear Couplings

RINGFEDER® TNZ ZCAF / TNZ ZCBF

Intermediate shaft and rigid counter-flanges

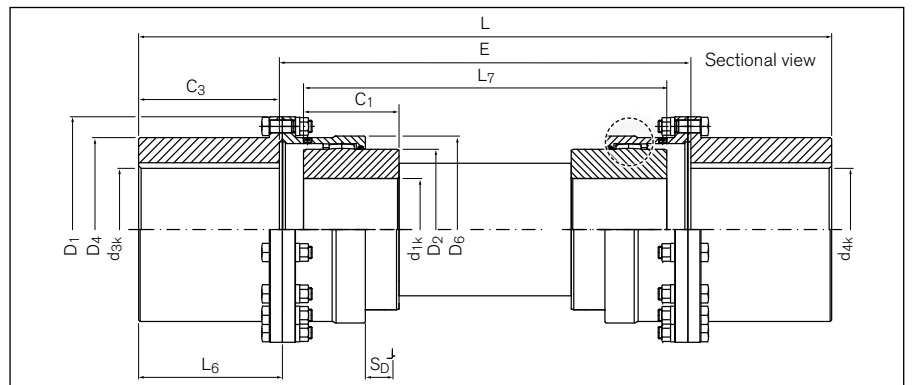
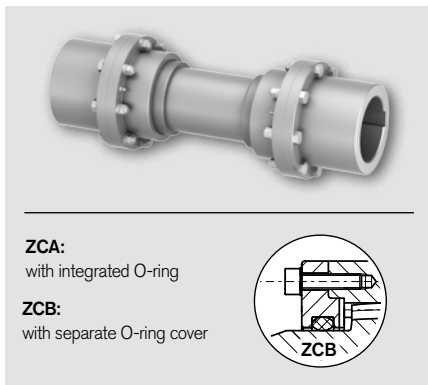

Identifier		Size	T _{KN}	T _{Kmax}	n _{max}	d _{1k} min-max	d _{3k} min-max	d _{4k} min-max	D ₁	D ₂	D ₄	D ₆	C ₁	C ₃
ZCAF	ZCBF		Nm	Nm	1/min	mm	mm	mm	mm	mm	mm	mm	mm	mm
XC6106	---	69	1750	3500	On request	12 - 50	12 - 55	0 - 55	111	69	80	81,5	43	40
XC6108	---	85	2750	5500		18 - 60	18 - 75	0 - 75	152	85	103,5	103,5	50	47
XC6110	XC7110	107	5500	11000		28 - 75	28 - 95	0 - 95	178	107	126	127,5	62	58
XC6113	XC7113	133	8500	17000		40 - 95	40 - 110	0 - 110	213	133	152	156	76	74
XC6115	XC7115	152	13500	2700		50 - 110	50 - 130	0 - 130	240	152	178	181	90	87
XC6117	XC7117	179	22000	44000		60 - 130	60 - 155	55 - 155	280	179	208	209	105	101
XC6120	XC7120	209	35000	70000		70 - 155	70 - 180	65 - 180	318	209	245	245,5	120	113
XC6123	XC7123	234	43000	86000		85 - 175	85 - 200	80 - 200	346	234	270	274	135	129
XC6125	XC7125	254	68000	136000		95 - 190	95 - 230	90 - 230	389	254	305	307	150	150
XC6127	XC7127	279	82000	164000		110 - 210	110 - 250	100 - 250	425	279	330	334,5	175	175
XC6130	XC7130	305	150000	300000		120 - 230	120 - 280	120 - 280	457	305	362	366	190	190
XC6135	XC7135	355	195000	390000		130 - 270	130 - 330	150 - 330	527	355	419	423	220	220

Identifier		Size	E _{min}	L	L ₆	L _{7min}	S _D	ΔK _r	ΔK _w	J	V _{GR}	G _{Wsb}
ZCAF	ZCBF		mm	mm	mm	mm	mm	mm	degree	10 ⁻³ kgm ²	dm ³	kg
XC6106	---	69	99	179	43,5	86	30	Depends on E	2 x 0,5	Depends on E	2 x 0,035	Depends on E
XC6108	---	85	119	213	50,5	100	37		2 x 0,5		2 x 0,040	
XC6110	XC7110	107	155	271	61,5	124	48		2 x 0,5		2 x 0,065	
XC6113	XC7113	133	177	325	77,5	152	56		2 x 0,5		2 x 0,110	
XC6115	XC7115	152	229	403	90,5	180	70		2 x 0,5		2 x 0,190	
XC6117	XC7117	179	264	466	104	210	79		2 x 0,5		2 x 0,290	
XC6120	XC7120	209	304	530	116,5	240	92		2 x 0,5		2 x 0,375	
XC6123	XC7123	234	344	602	133	270	103		2 x 0,5		2 x 0,625	
XC6125	XC7125	254	400	700	154	300	120		2 x 0,5		2 x 0,960	
XC6127	XC7127	279	456	806	179	350	136		2 x 0,5		2 x 1,335	
XC6130	XC7130	305	500	880	196	380	148		2 x 0,5		2 x 1,665	
XC6135	XC7135	355	590	1040	228	440	174		2 x 0,5		2 x 2,500	

- Examine the load capacity of the shaft-hub connection
- Hubs pilot bored, bore diameter 2 mm smaller than smallest finish bore diameter, without intermediate shaft

To continue see next page

Gear Couplings RINGFEDER® TNZ ZCAF / TNZ ZCBF

Explanation

T_{KN}	= Nom. Transmissible torque	D₁	= Outer diameter	L₆	= Length of basic part
T_{Kmax}	= Max. transmissible torque of the coupling	D₂	= Outer diameter hub	L_{7min}	= Min. length of the middle connection part
n_{max}	= Max. rotation speed	D₄	= Outer diameter hub	S_D	= Disassembly Space
d_{1kmin} ; d_{3kmin} ; d_{4kmin}	= Min. bore diameter d ₁ /d ₃ /d ₄ with keyway acc. to DIN 6885-1	D₆	= Diameter	ΔK_r	= Max. permissible radial misalignment
d_{1kmax} ; d_{2kmax}	= Max. bore diameter d ₁ /d ₂ with keyway acc. to DIN 6885-1	C₁	= Guided length in hub bore	ΔK_w	= Max. permissible angular misalignment
		C₃	= Guided length in hub bore	J	= Total moment of inertia
		E_{min}	= Min. gap width between left and right component	V_{GR}	= Grease volume
		L	= Total length	GW_{sb}	= Weight at smallest bore diameter

Ordering example

Identifier	Size	d _{1k}	d _{2k}	Further details
XC6127	279	180	230	*

^{*)} Without any other specification, we deliver as a standard: keyway acc. to DIN 6885-1, keyway side fit P9, bore tolerance H7; optional with set screw

Further information on
RINGFEDER® TNZ ZCAF / TNZ ZCBF
 on www.ringfeder.com

Disclaimer of liability

All technical details and notes are non-binding and cannot be used as a basis for legal claims. The user is obligated to determine whether the represented products meet his requirements. We reserve the right carry out modifications at any time in the interests of technical progress.

Gear Couplings

RINGFEDER® TNZ ZCAK / TNZ ZCBK

Type with limited end float

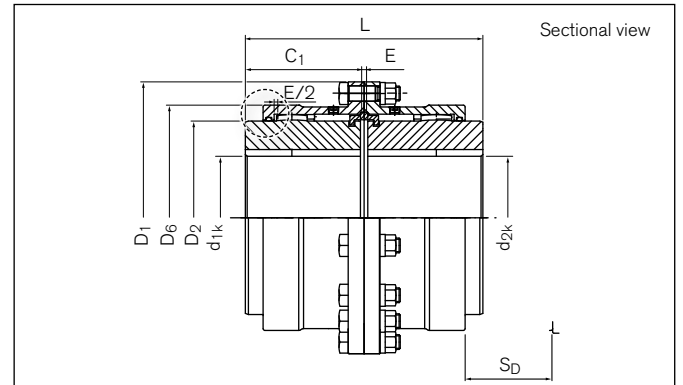
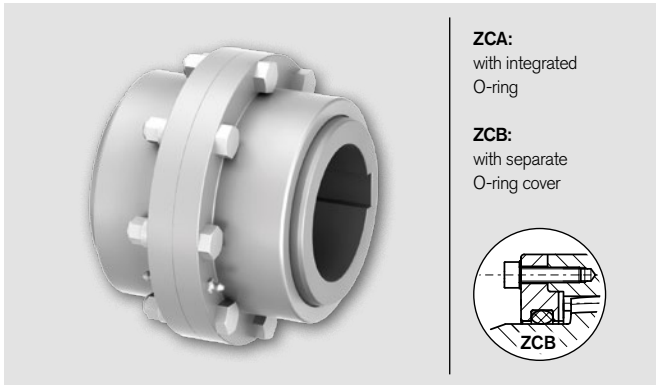

Identifier		Size	T _{KN}	T _{Kmax}	n _{max}	d _{1k} min-max	d _{2k} min-max	D ₁	D ₂	D ₆
ZCAK	ZCBK		Nm	Nm	1/min	mm	mm	mm	mm	mm
XC2706	---	69	1750	3500	6000	12 - 50	12 - 50	111	69	81,5
XC2708	---	85	2750	5500	4600	18 - 60	18 - 60	152	85	103,5
XC2710	XC3710	107	5500	11000	4200	28 - 75	28 - 75	178	107	127,5
XC2713	XC3713	133	8500	17000	4000	40 - 95	40 - 95	213	133	156
XC2715	XC3715	152	13500	27000	3850	50 - 110	50 - 110	240	152	181
XC2717	XC3717	179	22000	44000	3700	60 - 130	60 - 130	280	179	209
XC2720	XC3720	209	35000	70000	3200	70 - 155	70 - 155	318	209	245,5
XC2723	XC3723	234	43000	86000	2900	85 - 175	85 - 175	346	234	274
XC2725	XC3725	254	68000	136000	2600	95 - 190	95 - 190	389	254	307
XC2727	XC3727	279	82000	164000	2300	110 - 210	110 - 210	425	279	334,5
XC2730	XC3730	305	150000	300000	2100	120 - 230	120 - 230	457	305	366
XC2735	XC3735	355	195000	390000	1800	130 - 270	130 - 270	527	355	423

Limited end float adjustable depends on coupling size

Identifier		Size	C ₁	E	L	S _D	J	V _{GR}	G _{Wsb}
ZCAK	ZCBK		mm	mm	mm	mm	10 ⁻³ kgm ²	dm ³	kg
XC2706	---	69	43	3	89	30	4	2 x 0,035	4,0
XC2708	---	85	50	3	103	37	18	2 x 0,040	8,4
XC2710	XC3710	107	62	3	127	48	40	2 x 0,065	14,1
XC2713	XC3713	133	76	5	157	56	102	2 x 0,110	24,8
XC2715	XC3715	152	90	5	185	70	187	2 x 0,190	36,4
XC2717	XC3717	179	105	6	216	79	407	2 x 0,290	58,0
XC2720	XC3720	209	120	6	245	92	801	2 x 0,375	87,0
XC2723	XC3723	234	135	8	278	103	1248	2 x 0,625	113,7
XC2725	XC3725	254	150	8	308	120	2370	2 x 0,960	163,1
XC2727	XC3727	279	175	8	358	136	3638	2 x 1,335	215,4
XC2730	XC3730	305	190	8	388	148	4830	2 x 1,665	261,5
XC2735	XC3735	355	220	10	450	174	10022	2 x 2,500	409,2

- Examine the load capacity of the shaft-hub connection
- Hubs pilot bored, bore diameter 2 mm smaller than smallest finish bore diameter

To continue see next page

Gear Couplings RINGFEDER® TNZ ZCAK / TNZ ZCBK

Explanation

T_{KN}	= Nom. Transmissible torque	D₁	= Outer diameter	L₃	= Length
T_{Kmax}	= Max. transmissible torque of the coupling	D₂	= Outer diameter hub	S_D	= Disassembly Space
n_{max}	= Max. rotation speed	D₆	= Diameter	J	= Total moment of inertia
d_{1kmin}; d_{2kmin}	= Min. bore diameter d ₁ /d ₂ with keyway acc. to DIN 6885-1	C₁	= Guided length in hub bore	V_{GR}	= Grease volume
d_{1kmax}; d_{2kmax}	= Max. bore diameter d ₁ /d ₂ with keyway acc. to DIN 6885-1	E	= Gap width between left and right component	GW_{ub}	= Weight at smallest bore diameter
		L	= Total length		

Ordering example

Identifier	Size	d _{1k}	d _{2k}	Further details
XC2720	209	155	155	*

¹⁾ Without any other specification, we deliver as a standard: keyway acc. to DIN 6885-1, keyway side fit P9, bore tolerance H7; optional with set screw

Further information on
RINGFEDER® TNZ ZCAK / TNZ ZCBK
 on www.ringfeder.com

Disclaimer of liability

All technical details and notes are non-binding and cannot be used as a basis for legal claims. The user is obligated to determine whether the represented products meet his requirements. We reserve the right carry out modifications at any time in the interests of technical progress.

Gear Couplings

RINGFEDER®

TNZ ZCAUU / TNZ ZCBUU

Extended universal hubs

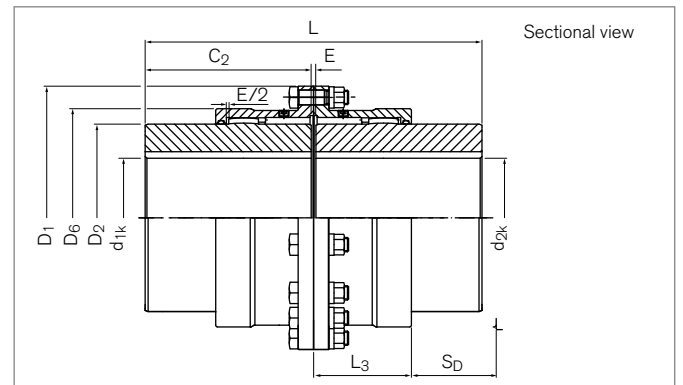
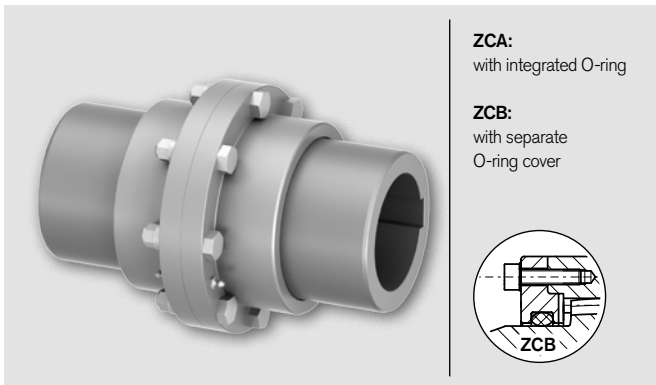

Identifier		Size	T_{KN}	T_{Kmax}	n_{max}	d_{1k} min-max	d_{2k} min-max	D_1	D_2	D_6	C_2
ZCAUU	ZCBUU		Nm	Nm	1/min	mm	mm	mm	mm	mm	mm
XC2306	---	69	1750	3500	6000	12 - 50	12 - 50	111	69	81,5	105
XC2308	---	85	2750	5500	4600	18 - 60	18 - 60	152	85	103,5	115
XC2310	XC3310	107	5500	11000	4200	28 - 75	28 - 75	178	107	127,5	130
XC2313	XC3313	133	8500	17000	4000	40 - 95	40 - 95	213	133	156	150
XC2315	XC3315	152	13500	27000	3850	50 - 110	50 - 110	240	152	181	170
XC2317	XC3317	179	22000	44000	3700	60 - 130	60 - 130	280	179	209	185
XC2320	XC3320	209	35000	70000	3200	70 - 155	70 - 155	318	209	245,5	215
XC2323	XC3323	234	43000	86000	2900	85 - 175	85 - 175	346	234	274	245
XC2325	XC3325	254	68000	136000	2600	95 - 190	95 - 190	389	254	307	295
XC2327	XC3327	279	82000	164000	2300	110 - 210	110 - 210	425	279	334,5	300
XC2330	XC3330	305	150000	300000	2100	120 - 230	120 - 230	457	305	366	305
XC2335	XC3335	355	195000	390000	1800	130 - 270	130 - 270	527	355	423	310

To continue see next page

Gear Couplings RINGFEDER® TNZ ZCAUU / TNZ ZCBUU

Identifier		Size	E	L	L ₃	S _D	ΔK _r	ΔK _w	J	V _{GR}	G _{Wsb}
ZCAUU	ZCBUU		mm	mm	mm	mm	mm		10 ⁻³ kgm ²	dm ³	kg
XC2306	---	69	3	213	39	80	0,42	2 x 0,5	6	0,07	7,5
XC2308	---	85	3	233	46	83	0,51	2 x 0,5	23	0,08	14,0
XC2310	XC3310	107	3	263	59	85	0,66	2 x 0,5	54	0,13	23,1
XC2313	XC3313	133	5	305	69	100	0,77	2 x 0,5	137	0,22	39,8
XC2315	XC3315	152	5	345	83	106	0,99	2 x 0,5	252	0,38	57,1
XC2317	XC3317	179	6	376	93	115	1,15	2 x 0,5	530	0,58	86,0
XC2320	XC3320	209	6	436	106	132	1,33	2 x 0,5	1077	0,75	133,1
XC2323	XC3323	234	8	498	118	151	1,5	2 x 0,5	1748	1,25	179,1
XC2325	XC3325	254	8	598	138	181	1,75	2 x 0,5	3283	1,92	263,7
XC2327	XC3327	279	8	608	154	185	1,99	2 x 0,5	4780	2,67	318,1
XC2330	XC3330	305	8	618	166	178	2,13	2 x 0,5	6329	3,33	374,4
XC2335	XC3335	355	10	630	193	174	2,55	2 x 0,5	12186	5	531,4

- Examine the load capacity of the shaft-hub connection
- Hubs pilot bored, bore diameter 2 mm smaller than smallest finish bore diameter

Explanation

T_{KN}	= Nom. Transmissible torque	D₁	= Outer diameter	L₃	= Length
T_{Kmax}	= Max. transmissible torque of the coupling	D₂	= Outer diameter hub	S_D	= Disassembly Space
n_{max}	= Max. rotation speed	D₆	= Diameter	ΔK_r	= Max. permissible radial misalignment
d_{1kmin}; d_{2kmin}	= Min. bore diameter d ₁ /d ₂ with keyway acc. to DIN 6885-1	C₂	= Guided length in hub bore	ΔK_w	= Max. permissible angular misalignment
d_{1kmax}; d_{2kmax}	= Max. bore diameter d ₁ /d ₂ with keyway acc. to DIN 6885-1	E	= Gap width between left and right component	J	= Total moment of inertia
		L	= Total length	V_{GR}	= Grease volume
				G_{Wsb}	= Weight at smallest bore diameter

Ordering example

Identifier	Size	d _{1k}	d _{2k}	Further details
XC2325	254	150	180	*

^{*)} Without any other specification, we deliver as a standard: keyway acc. to DIN 6885-1, keyway side fit P9, bore tolerance H7; optional with set screw

Further information on
RINGFEDER® TNZ ZCAUU / TNZ ZCBUU
 on www.ringfeder.com

Disclaimer of liability

All technical details and notes are non-binding and cannot be used as a basis for legal claims. The user is obligated to determine whether the represented products meet his requirements. We reserve the right carry out modifications at any time in the interests of technical progress.

Gear Couplings

RINGFEDER® TNZ ZCAU / TNZ ZCBU

Standard hub and extended universal hub

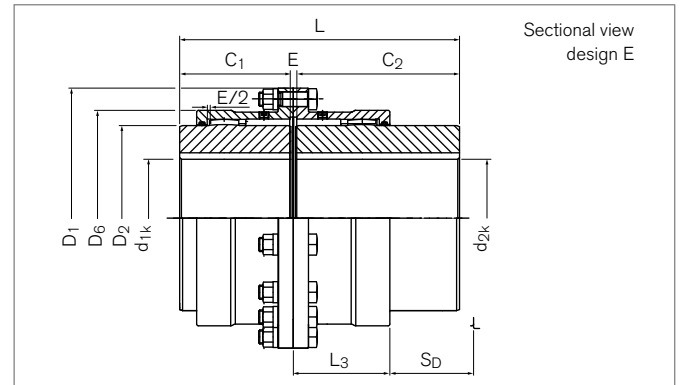
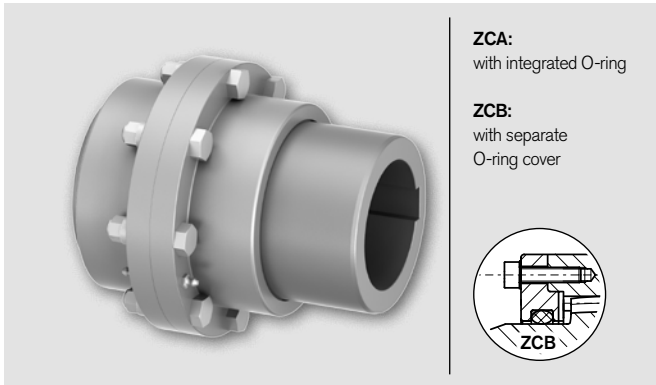

Identifier		Size	T _{KN}	T _{Kmax}	n _{max}	d _{1k} min-max	d _{2k} min-max	D ₁	D ₂	D ₆	C ₁	C ₂
ZCAU	ZCBU		Nm	Nm	1/min	mm	mm	mm	mm	mm	mm	mm
XC2206	---	69	1750	3500	6000	12 - 50	12 - 50	111	69	81,5	43	105
XC2208	---	85	2750	5500	4600	18 - 60	18 - 60	152	85	103,5	50	115
XC2210	XC3210	107	5500	11000	4200	28 - 75	28 - 75	178	107	127,5	62	130
XC2213	XC3213	133	8500	17000	4000	40 - 95	40 - 95	213	133	156	76	150
XC2215	XC3215	152	13500	27000	3850	50 - 110	50 - 110	240	152	181	90	170
XC2217	XC3217	179	22000	44000	3700	60 - 130	60 - 130	280	178	209	105	185
XC2220	XC3220	209	35000	70000	3200	70 - 155	70 - 155	318	209	245,5	120	215
XC2223	XC3223	234	43000	86000	2900	85 - 175	85 - 175	346	234	274	135	245
XC2225	XC3225	254	68000	136000	2600	95 - 190	95 - 190	389	254	307	150	295
XC2227	XC3227	279	82000	164000	2300	110 - 210	110 - 210	425	279	334,5	175	300
XC2230	XC3230	305	150000	300000	2100	120 - 230	120 - 230	457	305	366	190	305
XC2235	XC3235	355	195000	390000	1800	130 - 270	130 - 270	527	355	423	220	310

Identifier		Size	E	E _{I1}	L	L _{I1}	L ₃	S _D	ΔK _r	ΔK _w	J	V _{GR}	G _{w_{sb}}
ZCAU	ZCBU		mm	mm	mm	mm	mm	mm	mm	degree	10 ⁻³ kgm ²	dm ³	kg
XC2206	---	69	3	5	151	153	39	80	0,42	2 x 0,5	5	0,07	5,8
XC2208	---	85	3	8	168	173	46	83	0,51	2 x 0,5	18	0,08	11,2
XC2210	XC3210	107	3	14	195	206	59	85	0,66	2 x 0,5	40	0,13	18,6
XC2213	XC3213	133	5	12	231	238	69	100	0,77	2 x 0,5	120	0,22	32,3
XC2215	XC3215	152	5	24	265	284	83	106	1,00	2 x 0,5	220	0,38	46,7
XC2217	XC3217	179	6	27	296	317	93	115	1,15	2 x 0,5	469	0,58	72,0
XC2220	XC3220	209	6	32	341	367	106	132	1,33	2 x 0,5	939	0,75	110,1
XC2223	XC3223	234	8	37	388	417	118	151	1,5	2 x 0,5	1498	1,25	146,4
XC2225	XC3225	254	8	50	453	498	138	181	1,75	2 x 0,5	2827	1,92	213,4
XC2227	XC3227	279	8	53	483	528	154	185	1,99	2 x 0,5	4209	2,67	266,8
XC2230	XC3230	305	8	58	503	553	166	178	2,16	2 x 0,5	5580	3,33	317,9
XC2235	XC3235	355	10	72	540	602	193	174	2,55	2 x 0,5	11104	5,00	470,3

- Examine the load capacity of the shaft-hub connection
- Hubs pilot bored, bore diameter 2 mm smaller than smallest finish bore diameter

With inverted standard hub note EI1 and LI1

To continue see next page

Gear Couplings RINGFEDER® TNZ ZCAU / TNZ ZCBU

Explanation

T_{KN} = Nom. Transmissible torque	D₂ = Outer diameter hub	L₁₁; L₁₂ = Complete length of inverted variant 1/2
T_{Kmax} = Max. transmissible torque of the coupling	D₆ = Diameter	L₃ = Length
n_{max} = Max. rotation speed	C₁ = Guided length in hub bore	S_D = Disassembly Space
d_{1kmin}; d_{2kmin} = Min. bore diameter d ₁ /d ₂ with keyway acc. to DIN 6885-1	C₂ = Guided length in hub bore	ΔK_r = Max. permissible radial misalignment
d_{1kmax}; d_{2kmax} = Max. bore diameter d ₁ /d ₂ with keyway acc. to DIN 6885-1	E = Gap width between left and right component	ΔK_w = Max. permissible angular misalignment
D₁ = Outer diameter	E₁₁; E₁₂ = Gap width between left and right component of inverted variant 1/2	J = Total moment of inertia
	L = Total length	V_{GR} = Grease volume
		G_{wub} = Weight at smallest bore diameter

Ordering example

Identifier	Size	d _{1k}	d _{2k}	Further details
XC3215	152	90	110	*

¹⁾ Without any other specification, we deliver as a standard: keyway acc. to DIN 6885-1, keyway side fit P9, bore tolerance H7; optional with set screw

Further information on
RINGFEDER® TNZ ZCAU / TNZ ZCBU
 on www.ringfeder.com

Disclaimer of liability

All technical details and notes are non-binding and cannot be used as a basis for legal claims. The user is obligated to determine whether the represented products meet his requirements. We reserve the right carry out modifications at any time in the interests of technical progress.

Gear Couplings

RINGFEDER® TNZ ZCAV / TNZ ZCBV

Vertical construction

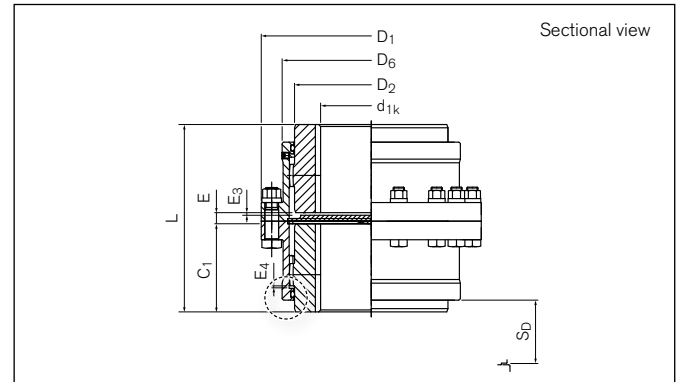
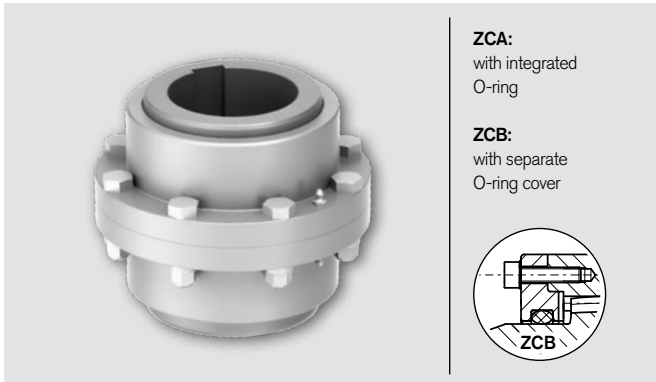

Identifier		Size	T _{KN}	T _{Kmax}	n _{max}	d _{1k} min-max	d _{2k} min-max	D ₁	D ₂	D ₆
ZCAV	ZCBV		Nm	Nm	1/min	mm	mm	mm	mm	mm
XC2606	---	69	1750	3500	6000	12 - 50	12 - 50	111	69	81,5
XC2608	---	85	2750	5500	4600	18 - 60	18 - 60	152	85	103,5
XC2610	XC3610	107	5500	11000	4200	28 - 75	28 - 75	178	107	127,5
XC2613	XC3613	133	8500	17000	4000	40 - 95	40 - 95	213	133	156
XC2615	XC3615	152	13500	27000	3850	50 - 110	50 - 110	240	152	181
XC2617	XC3617	179	22000	44000	3700	60 - 130	60 - 130	280	179	209
XC2620	XC3620	209	35000	70000	3200	70 - 155	70 - 155	318	209	245,5
XC2623	XC3623	234	43000	86000	2900	85 - 175	85 - 175	346	234	274
XC2625	XC3625	254	68000	136000	2600	95 - 190	95 - 190	389	254	307
XC2627	XC3627	279	82000	164000	2300	110 - 210	110 - 210	425	279	334,5
XC2630	XC3630	305	150000	300000	2100	120 - 230	120 - 230	457	305	366
XC2635	XC3635	355	195000	390000	1800	130 - 270	130 - 270	527	355	423

Identifier		Size	C ₁	E	E ₃	E ₄	L	S _D	ΔK _r	ΔK _w	J	V _{GR}	G _{w_{sb}}
ZCAV	ZCBV		mm	mm	mm	mm	mm	mm	mm	degree	10 ⁻³ kgm ²	dm ³	kg
XC2606	---	69	43	7	1,5	1,5	93	30	0,42	2 x 0,5	4	Follow lubrication instruction	4,1
XC2608	---	85	50	8	1,5	1,5	108	37	0,51	2 x 0,5	18		8,8
XC2610	XC3610	107	62	11	1,5	1,5	135	48	0,66	2 x 0,5	40		14,8
XC2613	XC3613	133	76	12	2,5	2,5	164	56	0,77	2 x 0,5	102		25,8
XC2615	XC3615	152	90	16,5	5,5	2,5	196	70	0,99	2 x 0,5	187		37,9
XC2617	XC3617	179	105	15	3	3	225	79	1,15	2 x 0,5	407		60,2
XC2620	XC3620	209	120	18	6	3	258	92	1,33	2 x 0,5	801		89,9
XC2623	XC3623	234	135	23	9	4	293	103	1,5	2 x 0,5	1248		117,9
XC2625	XC3625	254	150	34	20	4	334	120	1,75	2 x 0,5	2370		168,2
XC2627	XC3627	279	175	36	22	4	386	136	1,99	2 x 0,5	3638		221,8
XC2630	XC3630	305	190	38	24	4	418	148	2,16	2 x 0,5	4830		269,3
XC2635	XC3635	355	220	48	32	5	488	174	2,55	2 x 0,5	10022		421,7

- Examine the load capacity of the shaft-hub connection
- Hubs pilot bored, bore diameter 2 mm smaller than smallest finish bore diameter

Distance E may not vary during operation

To continue see next page

Gear Couplings RINGFEDER® TNZ ZCAV / TNZ ZCBV

Explanation

T_{KN}	= Nom. Transmissible torque	D₁	= Outer diameter	L	= Total length
T_{Kmax}	= Max. transmissible torque of the coupling	D₂	= Outer diameter hub	S_D	= Disassembly Space
n_{max}	= Max. rotation speed	D₆	= Diameter	ΔK_r	= Max. permissible radial misalignment
d_{1kmin}; d_{2kmin}	= Min. bore diameter d ₁ /d ₂ with keyway acc. to DIN 6885-1	C₁	= Guided length in hub bore	ΔK_w	= Max. permissible angular misalignment
d_{1kmax}; d_{2kmax}	= Max. bore diameter d ₁ /d ₂ with keyway acc. to DIN 6885-1	E	= Gap width between left and right component	J	= Total moment of inertia
		E₄	= Gap width	V_{GR}	= Grease volume
		E₃	= Gap width	Gw_{sb}	= Weight at smallest bore diameter

Ordering example

Identifier	Size	d _{1k}	d _{2k}	Further details
XC3630	305	140	220	*

¹⁾ Without any other specification, we deliver as a standard: keyway acc. to DIN 6885-1, keyway side fit P9, bore tolerance H7; optional with set screw

Further information on
RINGFEDER® TNZ ZCAV / TNZ ZCBV
 on www.ringfeder.com

Disclaimer of liability

All technical details and notes are non-binding and cannot be used as a basis for legal claims. The user is obligated to determine whether the represented products meet his requirements. We reserve the right carry out modifications at any time in the interests of technical progress.

Gear Couplings

RINGFEDER® TNZ ZCA / TNZ ZCB

Standard hubs

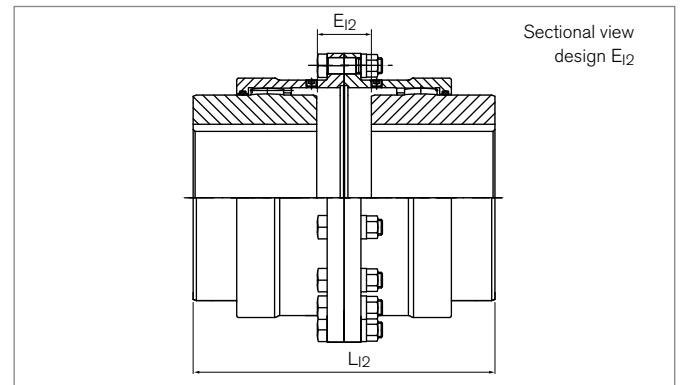
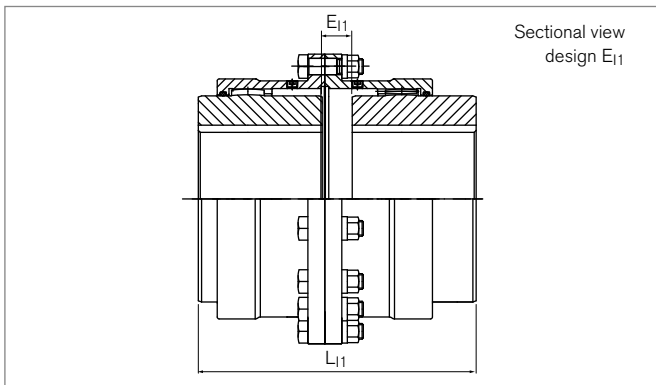
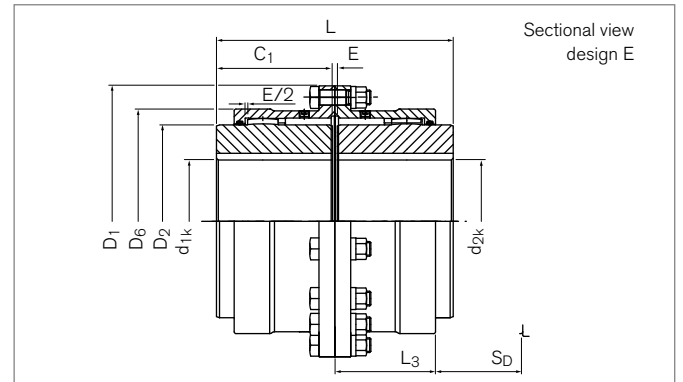
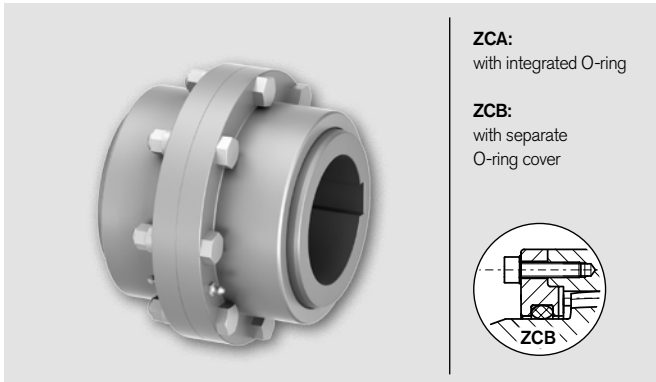

Identifier		Size	T _{KN}	T _{Kmax}	n _{max}	d _{1k} min-max	d _{2k} min-max	D ₁	D ₂	D ₆	C ₁
ZCA	ZCB		Nm	Nm	1/min	mm	mm	mm	mm	mm	mm
XC2106	---	69	1750	3500	6000	12 - 50	12 - 50	111	69	81,5	43
XC2108	---	85	2750	5500	4600	18 - 60	18 - 60	152	85	103,5	50
XC2110	XC3110	107	5500	11000	4200	28 - 75	28 - 75	178	107	127,5	62
XC2113	XC3113	133	8500	17000	4000	40 - 95	40 - 95	213	133	156	76
XC2115	XC3115	152	13500	27000	3850	50 - 110	50 - 110	240	152	181	90
XC2117	XC3117	179	22000	44000	3700	60 - 130	60 - 130	280	178	209	105
XC2120	XC3120	209	35000	70000	3200	70 - 155	70 - 155	318	209	245,5	120
XC2123	XC3123	234	43000	86000	2900	85 - 175	85 - 175	346	234	274	135
XC2125	XC3125	254	68000	136000	2600	95 - 190	95 - 190	389	254	307	150
XC2127	XC3127	279	82000	164000	2300	110 - 210	110 - 210	425	279	334,5	175
XC2130	XC3130	305	150000	300000	2100	120 - 230	120 - 230	457	305	366	190
XC2135	XC3135	355	195000	390000	1800	130 - 270	130 - 270	527	355	423	220

To continue see next page

Gear Couplings RINGFEDER® TNZ ZCA / TNZ ZCB

Identifier		Size	E	E ₁₁	E ₁₂	L	L ₁₁	L ₁₂	L ₃	S _D	ΔK _r	ΔK _w	J	V _{GR}	G _{w_{sb}}
ZCA	ZCB		mm	mm	mm	mm	mm	mm	mm	mm	mm	degree	10 ⁻³ kgm ²	dm ³	kg
XC2106	---	69	3	5	7	89	91	93	39	30	0,42	2 x 0,5	4	0,07	4,1
XC2108	---	85	3	8	13	103	108	113	46	37	0,51	2 x 0,5	18	0,08	8,7
XC2110	XC3110	107	3	14	25	127	138	149	59	48	0,66	2 x 0,5	40	0,13	14,4
XC2113	XC3113	133	5	12	19	157	164	171	69	56	0,77	2 x 0,5	102	0,22	25,6
XC2115	XC3115	152	5	24	43	185	204	223	83	70	0,99	2 x 0,5	187	0,38	37,3
XC2117	XC3117	179	6	27	48	216	237	258	93	79	1,15	2 x 0,5	407	0,58	58,9
XC2120	XC3120	209	6	32	58	246	272	298	106	92	1,33	2 x 0,5	801	0,75	88,6
XC2123	XC3123	234	8	37	66	278	307	336	118	103	1,5	2 x 0,5	1248	1,25	116,1
XC2125	XC3125	254	8	50	92	308	350	392	138	120	1,75	2 x 0,5	2370	1,92	166,0
XC2127	XC3127	279	8	53	98	358	403	448	154	136	1,99	2 x 0,5	3638	2,67	219,2
XC2130	XC3130	305	8	58	108	388	438	488	166	148	2,16	2 x 0,5	4830	3,33	265,9
XC2135	XC3135	355	10	72	134	450	512	574	193	174	2,55	2 x 0,5	10022	5,00	415,8

Explanation

T_{KN} = Nom. Transmissible torque	D₂ = Outer diameter hub	L₃ = Length
n_{max} = Max. transmissible torque of the coupling	D₆ = Diameter	S_D = Disassembly Space
d_{1kmin}; d_{2kmin} = Min. bore diameter d ₁ /d ₂ with keyway acc. to DIN 6885-1	C₁ = Guided length in hub bore	ΔK_r = Max. permissible radial misalignment
d_{1kmax}; d_{2kmax} = Max. bore diameter d ₁ /d ₂ with keyway acc. to DIN 6885-1	E = Gap width between left and right component	ΔK_w = Max. permissible angular misalignment
D₁ = Outer diameter	E₁₁; E₁₂ = Gap width between left and right component of inverted variant 1/2	J = Total moment of inertia
	L = Total length	V_{GR} = Grease volume
	L₁₁; L₁₂ = Complete length of inverted variant 1/2	G_{w_{ub}} = Weight at smallest bore diameter

Ordering example

Identifier	Size	d _{1k}	d _{2k}	Further details
XC2113	133	70	90	*

^{*)} Without any other specification, we deliver as a standard: keyway acc. to DIN 6885-1, keyway side fit P9, bore tolerance H7; optional with set screw

Further information on
RINGFEDER® TNZ ZCA / TNZ ZCB
 on www.ringfeder.com

Disclaimer of liability

All technical details and notes are non-binding and cannot be used as a basis for legal claims. The user is obligated to determine whether the represented products meet his requirements. We reserve the right carry out modifications at any time in the interests of technical progress.

Gear Couplings

RINGFEDER® TNZ ZCAZ / TNZ ZCBZ

Standard hubs and spacer

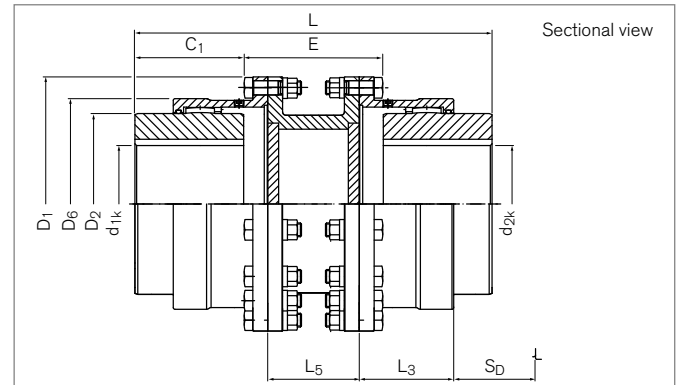
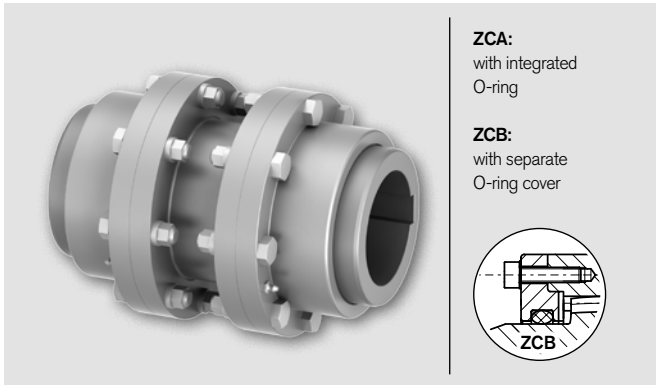

Identifier		Size	T _{KN}	T _{Kmax}	n _{max}	d _{1k} min-max	d _{2k} min-max	D ₁	D ₂	D ₆	C ₁
ZCAZ	ZCBZ		Nm	Nm	1/min	mm	mm	mm	mm	mm	mm
XC4106	---	69	1750	3500	On request	12 - 50	12 - 50	111	69	81,5	43
XC4108	---	85	2750	5500		18 - 60	18 - 60	152	85	103,5	50
XC4110	XC5110	107	5500	11000		28 - 75	28 - 75	178	107	127,5	62
XC4113	XC5113	133	8500	17000		40 - 95	40 - 95	213	133	156	76
XC4115	XC5115	152	13500	27000		50 - 110	50 - 110	240	152	181	90
XC4117	XC5117	179	22000	44000		60 - 130	60 - 130	280	179	209	105
XC4120	XC5120	209	35000	44000		70 - 155	70 - 155	318	209	245,5	120
XC4123	XC5123	234	43000	86000		85 - 175	85 - 175	346	234	274	135
XC4125	XC5125	254	68000	136000		95 - 190	95 - 190	389	254	307	150
XC4127	XC5127	279	82000	164000		110 - 210	110 - 210	425	279	334,5	175
XC4130	XC5130	305	150000	300000		120 - 230	120 - 230	457	305	366	190
XC4135	XC5135	355	195000	390000		130 - 270	130 - 270	527	355	423	220

Identifier		Size	E _{min}	L _{min}	L ₃	L _{5min}	S _D	ΔK _r	ΔK _w	J	V _{GR}	G _{Wsb}
ZCAZ	ZCBZ		mm	mm	mm	mm	mm	mm	degree	10 ⁻³ kgm ²	dm ³	kg
XC4106	---	69	67	153	39	60	30	Depends on E	2 x 0,5	Depends on E	2 x 0,035	Depends on E
XC4108	---	85	93	193	46	80	37		2 x 0,5		2 x 0,040	
XC4110	XC5110	107	115	239	59	90	48		2 x 0,5		2 x 0,065	
XC4113	XC5113	133	129	281	69	110	56		2 x 0,5		2 x 0,110	
XC4115	XC5115	152	153	333	83	110	70		2 x 0,5		2 x 0,190	
XC4117	XC5117	179	178	388	93	130	79		2 x 0,5		2 x 0,290	
XC4120	XC5120	209	188	428	106	130	92		2 x 0,5		2 x 0,375	
XC4123	XC5123	234	196	466	118	130	103		2 x 0,5		2 x 0,625	
XC4125	XC5125	254	252	552	138	160	120		2 x 0,5		2 x 0,960	
XC4127	XC5127	279	258	608	154	160	136		2 x 0,5		2 x 1,335	
XC4130	XC5130	305	268	648	166	160	148		2 x 0,5		2 x 1,665	
XC4135	XC5135	355	294	734	193	160	174		2 x 0,5		2 x 2,500	

- Examine the load capacity of the shaft-hub connection
- Hubs pilot bored, bore diameter 2 mm smaller than smallest finish bore diameter

To continue see next page

Gear Couplings RINGFEDER® TNZ ZCAZ / TNZ ZCBZ

Explanation

T_{KN} = Nom. Transmissible torque	D₁ = Outer diameter	L_{5min} = Min. length of spacer
T_{Kmax} = Max. transmissible torque of the coupling	D₂ = Outer diameter hub	S_D = Disassembly Space
n_{max} = Max. rotation speed	D₆ = Diameter	ΔK_r = Max. permissible radial misalignment
d_{1kmin};d_{2kmin} = Min. bore diameter d ₁ /d ₂ with keyway acc. to DIN 6885-1	C₁ = Guided length in hub bore	ΔK_w = Max. permissible angular misalignment
d_{1kmax};d_{2kmax} = Max. bore diameter d ₁ /d ₂ with keyway acc. to DIN 6885-1	E_{min} = Min. gap width between left and right component	J = Total moment of inertia
	L_{min} = Minimum length	V_{GR} = Grease volume
	L₃ = Length	Gw_{sb} = Weight at smallest bore diameter

Ordering example

Identifier	Size	d _{1k}	d _{2k}	Further details
XC5117	179	120	120	*

^{*)} Without any other specification, we deliver as a standard: keyway acc. to DIN 6885-1, keyway side fit P9, bore tolerance H7; optional with set screw

Further information on
RINGFEDER® TNZ ZCAZ / TNZ ZCBZ
 on www.ringfeder.com

Disclaimer of liability

All technical details and notes are non-binding and cannot be used as a basis for legal claims. The user is obligated to determine whether the represented products meet his requirements. We reserve the right carry out modifications at any time in the interests of technical progress.

Gear Couplings

RINGFEDER® TNZ ZCH

Standard hubs with one-piece casing

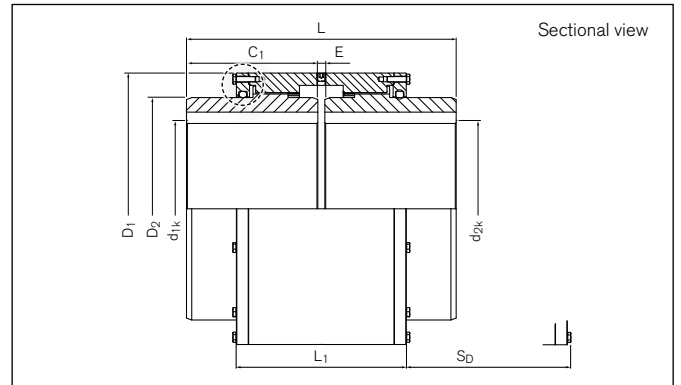
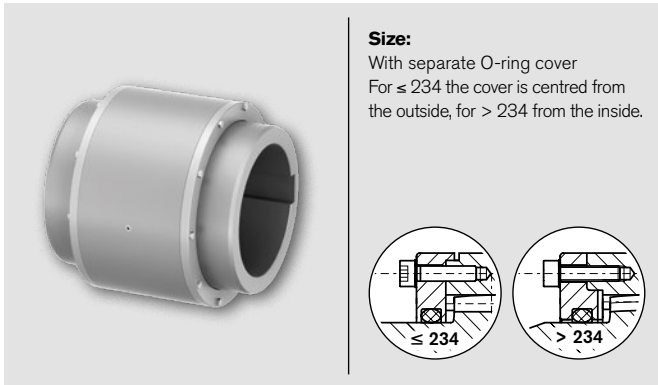

Identifier	Size	T_{KN}	T_{Kmax}	n_{max}	d_{1k} min-max	d_{2k} min-max	D_1	D_2
ZCH		Nm	Nm	1/min	mm	mm	mm	mm
XCD106	69	1750	3500	6000	12 - 50	12 - 50	98	69
XCD108	85	2750	5500	4600	18 - 60	18 - 60	115	85
XCD110	107	5500	11000	4200	28 - 75	28 - 75	145	107
XCD113	133	8500	17000	4000	40 - 95	40 - 95	176	133
XCD115	152	13500	27000	3850	50 - 110	50 - 110	196	152
XCD117	179	22000	44000	3700	60 - 130	60 - 130	225	179
XCD120	209	35000	70000	3200	70 - 155	70 - 155	256	209
XCD123	234	43000	86000	2900	85 - 175	85 - 175	286	234
XCD125	254	68000	136000	2600	95 - 190	95 - 190	310	254
XCD127	279	82000	164000	2300	110 - 210	110 - 210	345	279
XCD130	305	150000	300000	2100	120 - 230	120 - 230	375	305
XCD135	355	195000	390000	1800	130 - 270	130 - 270	430	355

Identifier	Size	C_1	E	L	L_1	S_D	ΔK_r	ΔK_w	J	V_{GR}	G_{Wsb}
ZCH		mm	mm	mm	mm	mm	mm	degree	$10^{-3}kgm^2$	dm^3	kg
XCD106	69	43	3	89	76	30	0,42	2 x 0,5	6	0,07	4,6
XCD108	85	50	3	103	83	37	0,51	2 x 0,5	11	0,08	7,0
XCD110	107	62	3	127	94	48	0,66	2 x 0,5	33	0,13	13,3
XCD113	133	76	5	157	123	56	0,77	2 x 0,5	93	0,22	24,5
XCD115	152	90	5	185	127	70	0,99	2 x 0,5	155	0,38	33,8
XCD117	179	105	6	216	144	79	1,15	2 x 0,5	327	0,58	50,5
XCD120	209	120	6	246	160	92	1,33	2 x 0,5	595	0,75	75,9
XCD123	234	135	8	278	178	103	1,50	2 x 0,5	1040	1,25	104,7
XCD125	254	150	8	308	194	120	1,75	2 x 0,5	1551	1,92	131,7
XCD127	279	175	8	358	220	136	1,99	2 x 0,5	2713	2,67	185,4
XCD130	305	190	8	388	234	148	2,16	2 x 0,5	4071	3,33	236,6
XCD135	355	220	10	450	264	174	2,16	2 x 0,5	8208	5,00	368,0

- Examine the load capacity of the shaft-hub connection
- Hubs pilot bored, bore diameter 2 mm smaller than smallest finish bore diameter

To continue see next page

Gear Couplings RINGFEDER® TNZ ZCH

Explanation

T_{KN} = Nom. Transmissible torque	D₁ = Outer diameter	S_D = Disassembly Space
T_{Kmax} = Max. transmissible torque of the coupling	D₂ = Outer diameter hub	ΔK_r = Max. permissible radial misalignment
n_{max} = Max. rotation speed	C₁ = Guided length in hub bore	ΔK_w = Max. permissible angular misalignment
d_{1kmin}; d_{2kmin} = Min. bore diameter d ₁ /d ₂ with keyway acc. to DIN 6885-1	E = Gap width between left and right component	J = Total moment of inertia
d_{1kmax}; d_{2kmax} = Max. bore diameter d ₁ /d ₂ with keyway acc. to DIN 6885-1	L = Total length	V_{GR} = Grease volume
	L₁ = Overall length (without screws)	GW_{sb} = Weight at smallest bore diameter

Ordering example

Identifier	Size	d _{1k}	d _{2k}	Further details
XC0120	209	140	155	*

¹⁾ Without any other specification, we deliver as a standard: keyway acc. to DIN 6885-1, keyway side fit P9, bore tolerance H7; optional with set screw

Further information on
RINGFEDER® TNZ ZCH
 on www.ringfeder.com

Disclaimer of liability

All technical details and notes are non-binding and cannot be used as a basis for legal claims. The user is obligated to determine whether the represented products meet his requirements. We reserve the right carry out modifications at any time in the interests of technical progress.