

Shrink Discs

RINGFEDER® RfN 4051

Lighter version for moderate transfer values – particularly suited for thin hubs and hollow shafts

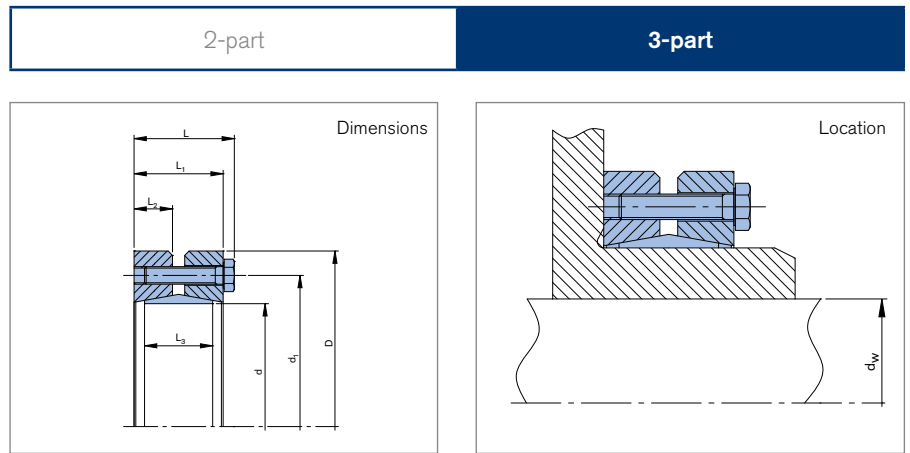

Shrink Discs dimensions								Transmissible torques or axial forces				Locking screws ISO 4014/4017 - 10.9					
d	x	D	d _w	d ₁	L	L ₁	L ₂	L ₃	T _A	T	F _{ax}	P	σ _v	Quantity	Thread	G _w	T _{max}
mm		mm		mm				Nm	Nm	kN	N/mm ²	N/mm ²			kg	Nm	
125	x	185	95	158	58	51	22	39	59	10.550	220	191	278	8	M10	5,1	13.200
			100							12.100	240		280				15.125
			105							13.800	260		288				17.250
140	x	220	110	175	58	51	22	39	59	14.800	265	192	268	9	M10	8	18.500
			120							18.640	310		281				23.300
			125							20.500	325		315				25.625
155	x	245	130	192	58	51	22	39	59	24.000	365	212	293	11	M10	10	30.000
			135							26.400	390		306				33.000
			140							29.000	410		334				36.250
165	x	260	135	210	70	62	26	46	100	32.000	475	224	298	10	M12	14	40.000
			140							35.200	500		308				44.000
			145							38.500	530		327				48.125
175	x	275	145	220	70	62	26	46	100	39.000	535	232	302	11	M12	14,7	48.750
			150							42.400	560		313				53.000
			155							46.000	590		334				57.500
185	x	295	155	225	70	62	26	46	100	46.600	600	240	307	12	M12	17,2	58.250
			160							50.300	625		319				62.875
			165							54.000	650		341				67.500
195	x	315	165	237	80	72	31	56	100	63.000	760	233	306	15	M12	23,8	78.750
			170							67.700	795		323				84.625
			175							72.500	825		355				90.625
200	x	330	175	242	80	72	31	56	100	74.000	850	243	334	16	M12	26,8	92.500
			180							79.500	890		368				99.375
			185							84.500	915		440				105.625

To continue see next page

Shrink Discs RINGFEDER® RfN 4051

Shrink Discs dimensions								Transmissible torques or axial forces				Locking screws ISO 4014/4017 - 10.9					
d	x	D	d _w	d ₁	L	L ₁	L ₂	L ₃	T _A	T	F _{ax}	P	σ _v	Quantity	Thread	Gw	T _{max}
mm		mm		mm				Nm	Nm	kN	N/mm ²	N/mm ²			kg	Nm	
220	x	345	180	265	94	84	36	66	250	82.800	920	220	277	10	M16	32	103.500
			190							93.500	980		306				116.875
			200							105.000	1.055		367				131.250
240	x	370	200	290	94	84	36	66	250	113.000	1.135	243	304	12	M16	36	141.250
			210							127.500	1.210		330				159.375
			215							134.500	1.250		356				168.125
260	x	395	220	310	102	92	40	72	250	149.000	1.350	240	303	14	M16	48	186.250
			230							165.000	1.435		334				206.250
			235							173.000	1.475		364				216.250
280	x	425	230	333	114	104	46	84	250	171.000	1.485	218	270	16	M16	60	213.750
			240							189.000	1.570		287				236.250
			250							208.000	1.660		324				260.000
300	x	460	250	358	114	104	46	84	250	215.000	1.720	229	279	18	M16	70	268.750
			260							234.000	1.800		303				292.500
			270							255.000	1.890		342				318.750
320	x	495	270	378	116	106	48	84	250	260.000	1.940	239	293	20	M16	84	325.000
			280							284.000	2.030		313				355.000
			290							306.000	2.125		355				382.500
340	x	535	290	402	116	106	48	84	250	300.000	2.070	236	288	21	M16	100	375.000
			300							324.000	2.160		309				405.000
			305							337.000	2.210		326				421.250
350	x	545	300	413	135	122	54	100	490	372.000	2.485	230	292	16	M16	120	465.000
			305							385.000	2.540		304				481.250
			310							400.000	2.590		320				500.000
360	x	555	300	423	135	122	54	100	490	360.000	2.400	223	270	16	M20	125	450.000
			310							388.000	2.500		284				485.000
			320							415.000	2.590		314				518.750
380	x	585	320	442	149	136	60	112	490	435.000	2.720	213	268	18	M20	150	543.750
			325							451.000	2.780		275				563.750
			330							467.000	2.835		285				583.750
390	x	595	330	452	149	136	60	112	490	505.000	3.060	230	285	20	M20	156	631.250
			340							540.000	3.175		304				675.000
			350							577.000	3.295		337				721.250
400	x	615	340	462	149	136	60	112	490	550.000	3.235	236	291	21	M20	164	687.500
			350							587.000	3.360		311				733.750
			360							626.000	3.480		345				782.500
420	x	630	350	485	157	144	64	120	490	578.000	3.300	219	265	22	M20	185	722.500
			360							617.000	3.425		277				771.250
			370							655.000	3.545		297				818.750
440	x	660	370	505	157	144	64	120	490	677.000	3.660	229	274	24	M20	205	846.250
			380							719.000	3.785		287				898.750
			390							762.000	3.910		309				952.500
460	x	685	390	527	171	158	71	132	490	840.000	4.320	232	283	28	M20	235	1.050.000
			400							890.000	4.460		299				1.112.500
			410							935.000	4.580		328				1.170.000

To continue see next page

Shrink Discs RINGFEDER® RfN 4051

Shrink Discs dimensions								Transmissible torques or axial forces			Locking screws ISO 4014/4017 - 10.9						
d	x	D	d _w	d ₁	L	L ₁	L ₂	L ₃	T _A	T	F _{ax}	P	σ _v	Quantity	Thread	G _w	T _{max}
mm		mm		mm				Nm	Nm	kN	N/mm ²	N/mm ²			kg	Nm	
480	x	715	410	547	171	158	71	132	490	891.000	4.350	222	275	28	M20	255	1.113.750
			420							941.000	4.480		290				1.176.250
			425							966.000	4.548		301				1.207.500
500	x	750	425	567	171	158	71	132	490	986.000	4.645	228	275	30	M20	285	1.232.500
			430							1.013.000	4.712		281				1.266.250
			440							1.066.000	4.845		297				1.332.500

More sizes on request

Explanation

d = Inner diameter	L₂ = Thrust ring width	P = Hub surface pressure
D = Outer diameter	L₃ = Width of ring	σ_v = Equivalent stress in the hub
d_w = Solid shaft diameter	L_B = Width of the half Shrink Disc	n_{sc} = Quantity of screws
d₁ = Pitch circle diameter	T_A = Max tightened torque of the clamping screws	D_G = Thread
L = Overall length	T = Transmissible torque at given T _A	G_w = Weight
L₁ = Overall length (without screws)	F_{ax} = Transmissible axial force	T_{max} = Max. transmissible torque

Ordering example

Series	d	D
RfN 4051	420	630

Table Clearance

d _w		ISO	Max. clearance S mm
above	up to		
6	10	H6/j6	0,011
10	18		0,014
18	30		0,017
30	50	H6/h6	0,032
50	80	H6/g6	0,048
80	120	H7/g6	0,069
120	180		0,079
180	250		0,090
250	315		0,101
315	400		0,111
400	500		0,123
500	630		0,136
630	800		0,154

Clearances considered for the calculation of the function values

Technical information

- Surface finishes: For shaft R_a ≤ 3,2 μm
- Tolerances: For shaft see table
- When using a hollow shaft instead of a solid shaft please contact our Engineering-Team.
- Additional loads, e.g. tension, thrust or bending have to be taken into consideration accordingly
- Function values: The functional characteristics are valid with the screw tightening torque listed in the tables and the following assumed conditions: The locking screws are lubricated using MoS₂ (μ_{tot} = 0,1). The tapered cones are lubricated using MoS₂ (μ = 0,05). The contact surfaces (d_w) are in lightly oiled condition with coefficient of friction μ = 0,12. The hub and shaft materials have a modulus of elasticity of 210,000 N/mm². (Lower values result in increased values for T and Fax with reduced tangential stress.) The maximum clearance S is being fully utilized. The shaft being used is solid, for hollow shaft applications the functional values will change. In cases where the assumed conditions do not apply then contact our Technical Department where we will be happy to assist you with your application.

Further information on
RINGFEDER® RfN 4051
 on www.ringfeder.com

Disclaimer of liability

All technical details and notes are non-binding and cannot be used as a basis for legal claims. The user is obligated to determine whether the represented products meet his requirements. We reserve the right carry out modifications at any time in the interests of technical progress.

Shrink Discs

RINGFEDER® RfN 4061

Standard series for high torque

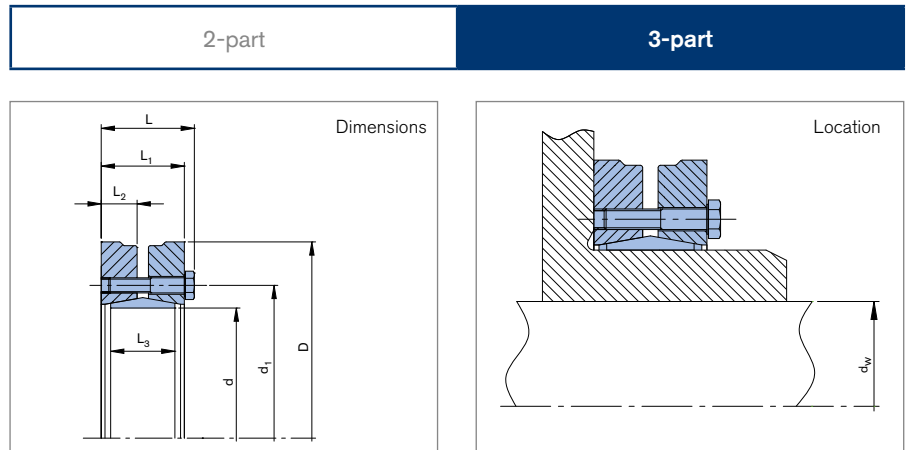

Shrink Discs dimensions									Transmissible torques or axial forces				Locking screws				
d	x	D	d _w	d ₁	L ₁	L ₂	L ₃	L _B	T _A	T	F _{ax}	P	σ _v	n _{sc}	D _G	G _w	T _{max}
mm			mm	mm	mm	mm	mm	mm	Nm	Nm	kN	N/mm ²	N/mm ²	Stück	mm	kg	Nm
14	x	37	10	24	12	5	9	9,5	2,4	30	8	278	415	3	M4 ¹⁾	0,1	37,5
			37							8	474		46				
			48							10	557		60				
16	x	41	12	27	15	6,25	12	9,5	4	70	15	336	509	4	M5	0,1	90
			90							18	575		110				
			110							20	774		130				
18	x	44	14	29	15	6,25	12	9,5	4	90	16	299	459	4	M5	0,2	110
			100							18	523		130				
			120							20	705		160				
20	x	46	15	32	17,5	7	12	11,5	4	110	20	336	462	5	M5	0,2	140
			140							22	497		170				
			160							24	580		200				
21	x	50	16	36	19	8	15	11,8	5	200	31	384	534	6	M5	0,2	250
			230							34	602		290				
			260							37	746		330				
24	x	50	19	36	19	8	15	11,8	5	240	32	336	495	6	M5	0,2	300
			270							35	554		340				
			300							38	679		390				
30	x	52	24	41,5	22,5	9,5	18	12,8	5	350	38	261	390	7	M5	0,2	450
			400							41	426		500				
			440							43	492		560				
36	x	72	28	52	23,5	10	18	13,8	12	590	53	303	390	5	M6	0,5	730
			690							58	438		860				
			700							58	536		890				

¹⁾ Different quality of screws. ISO 4014/4017 - 8.8

To continue see next page

Shrink Discs RINGFEDER® RfN 4061

Shrink Discs dimensions									Transmissible torques or axial forces				Locking screws				
d	x	D	d _w	d ₁	L ₁	L ₂	L ₃	L _B	T _A	T	F _{ax}	P	σ _v	n _{Sc}	D _G	G _w	T _{max}
mm			mm	mm	mm	mm	mm	mm	Nm	Nm	kN	N/mm ²	N/mm ²	Stück	mm	kg	Nm
38	x	72	29	55	26	10,5	21	15,2	12	700	62	295	378	6	M6	0,5	890
			30							770	65		394				970
			31							780	63		474				980
40	x	72	30	57	24,5	10,5	19	14,8	12	720	61	310	375	6	M6	0,5	900
			31							730	59		450				910
			32							790	62		460				990
44	x	80	32	63	26	11	20	15,3	12	800	63	312	429	7	M6	0,5	1000
			35							1000	73		444				1250
			36							1050	76		458				1350
48	x	80	36	68	26	11	22	15,8	12	900	65	260	371	7	M6	0,6	1150
			38							1050	72		380				1350
			40							1200	78		403				1550
50	x	90	38	70	27,5	12	22,5	16,3	12	1350	89	314	418	9	M6	0,9	1650
			40							1500	96		433				1900
			42							1700	103		467				2150
55	x	100	42	75	30,5	13	23	17,8	12	1300	78	248	343	8	M6	1,1	1600
			45							1550	87		359				1950
			48							1800	96		410				2300
62	x	110	48	86	30,5	13	23	17,8	12	2400	126	330	407	12	M6	1,3	3000
			50							2650	133		419				3300
			52							2800	136		482				3500
68	x	115	50	86	30,5	13	23,5	17,8	12	1900	95	245	314	10	M6	1,4	2350
			55							2250	104		367				2850
			60							2850	121		411				3600
75	x	138	55	100	32,5	14	25	19,7	30	2650	121	277	377	7	M8	2,3	3300
			60							3300	139		382				4150
			65							4050	158		416				5100
80	x	145	60	100	32,5	14	25	19,7	30	3200	126	259	353	7	M8	2,5	4000
			65							3900	143		358				4900
			70							4600	160		392				5750
85	x	155	60	114	40,5	16	30	23	30	4850	189	325	404	11	M8	3,5	6050
			65							5800	212		407				7250
			70							6800	235		427				8500
90	x	155	65	114	39	17	30	23	30	4800	174	274	353	10	M8	3,3	6000
			70							6050	195		356				7550
			75							7300	215		372				9150
95	x	170	65	127	47,2	19	34	23,5	30	5350	195	275	349	12	M8	4,7	6700
			70							6750	217		349				8450
			75							8150	240		355				10200
100	x	170	70	127	47,2	19	34	25,5	30	6950	202	261	331	12	M8	4,5	8700
			75							7600	223		331				9500
			80							9100	245		338				11350
110	x	185	75	145	53	23	42	28,5	59	8150	259	254	316	10	M10	6,3	10150
			80							10100	285		316				12600
			85							12200	296		357				15250
115	x	185	80	145	56	23	42	32	59	9500	267	243	302	10	M10	6,1	11850
			90							12100	302		342				15100
			95							14050	329		353				17550

To continue see next page

Shrink Discs RINGFEDER® RfN 4061

Shrink Discs dimensions								Transmissible torques or axial forces				Locking screws					
d	x	D	d _w	d ₁	L ₁	L ₂	L ₃	L _B	T _A	T	F _{ax}	P	σ _v	n _{sc}	D _G	G _w	T _{max}
mm			mm	mm	mm	mm	mm	mm	Nm	Nm	kN	N/mm ²	N/mm ²	Stück	mm	kg	Nm
125	x	215	85	160	54	23	42	32	59	11050	300	269	354	12	M10	8,7	13800
			90							13100	327		352				16350
			95							15150	355		352				18950
140	x	230	95	175	60,5	26	46	35,5	100	15100	365	263	336	10	M12	10,6	18850
			100							17550	395		335				21900
			105							20000	424		335				25000
155	x	265	105	192	64,5	28	50	37,2	100	22000	447	263	320	12	M12	15	27500
			110							25000	478		320				31250
			115							28000	509		322				35000
165	x	290	115	210	71	31	56	40,5	250	31400	601	280	334	8	M16	21,7	39300
			120							35500	637		335				44400
			125							39400	664		348				49250
175	x	300	125	220	71	31	56	40,5	250	36000	605	261	334	8	M16	22	45000
			130							41000	639		321				51250
			135							45000	675		324				56250
185	x	330	135	236	86,4	38,2	71	48	250	52500	786	246	307	10	M16	36	65600
			140							57350	828		310				71650
			145							62400	870		314				78000
195	x	350	140	246	86	38,2	71	48	250	65950	943	280	332	12	M16	40	82450
			150							77600	1035		338				97000
			155							83750	1081		345				104700
200	x	350	150	246	86	38,2	71	48	250	75000	1000	273	326	12	M16	39	93750
			155							81000	1045		330				101200
			160							87200	1091		337				109000

More sizes on request
To continue see next page

Shrink Discs RINGFEDER® RfN 4061

Explanation

d = Inner diameter	L₃ = Width of ring	σ_v = Equivalent stress in the hub
D = Outer diameter	L_B = Width of the half Shrink Disc	n_{sc} = Quantity of screws
d_w = Solid shaft diameter	T_A = Max tightened torque of the clamping screws	D_G = Thread
d₁ = Pitch circle diameter	T = Transmissible torque at given T _A	G_w = Weight
L₁ = Overall length (without screws)	F_{ax} = Transmissible axial force	T_{max} = Max. transmissible torque
L₂ = Thrust ring width	P = Hub surface pressure	

Ordering example

Series	d	D	Version
RfN 4061	185	330	
RfN 4061	185	330	N

N = Nickel plated series

Table Clearance

d _w		ISO	Max. clearance S mm
above	up to		
6	10	H6/j6	0,011
10	18		0,014
18	30		0,017
30	50	H6/h6	0,032
50	80	H6/g6	0,048
80	120	H7/g6	0,069
120	180		0,079
180	250		0,090
250	315		0,101
315	400		0,111
400	500		0,123
500	630		0,136
630	800	0,154	

Technical information

- Surface finishes: For shaft R_a ≤ 3,2 μm
- Tolerances: For shaft see table
- When using a hollow shaft instead of a solid shaft please contact our Engineering-Team.
- Additional loads, e.g. tension, thrust or bending have to be taken into consideration accordingly
- Function values: The functional characteristics are valid with the screw tightening torque listed in the tables and the following assumed conditions: The locking screws are lubricated using MoS₂ (μ_{tot} = 0,1). The tapered cones are lubricated using MoS₂ (μ = 0,05). The contact surfaces (d_w) are in lightly oiled condition with coefficient of friction μ = 0,12. The hub and shaft materials have a modulus of elasticity of 210,000 N/mm². (Lower values result in increased values for T and Fax with reduced tangential stress.) The maximum clearance S is being fully utilized. The shaft being used is solid, for hollow shaft applications the functional values will change. In cases where the assumed conditions do not apply then contact our Technical Department where we will be happy to assist you with your application.

Clearances considered for the calculation of the function values

Further information on
RINGFEDER® RfN 4061 on
www.ringfeder.com

Disclaimer of liability

All technical details and notes are non-binding and cannot be used as a basis for legal claims. The user is obligated to determine whether the represented products meet his requirements. We reserve the right carry out modifications at any time in the interests of technical progress.

Shrink Discs

RINGFEDER® RfN 4061 stainless steel

Corrosion resistant series for high torques

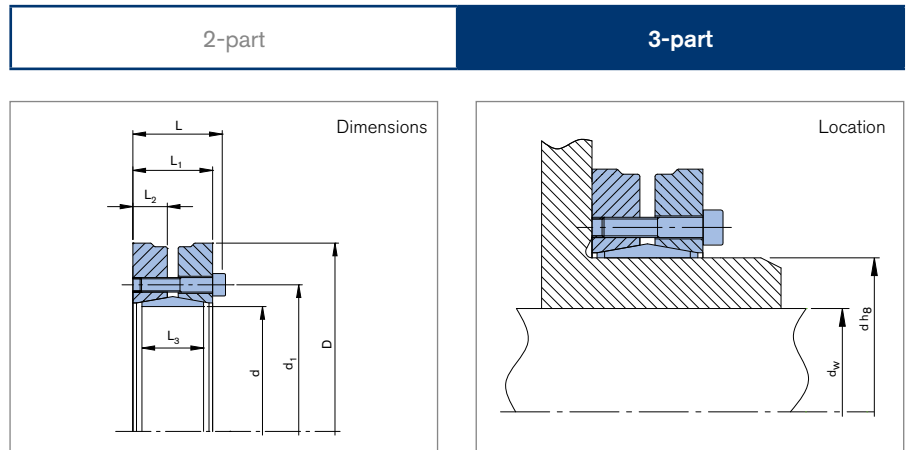

Shrink Discs dimensions									Transmissible torques or axial forces				High-strength special screws ISO 4762				
d	x	D	d _w	d ₁	L	L ₁	L ₂	L ₃	T _A	T	F _{ax}	P	σ _v	n _{Sc}	D _G	G _w	T _{max}
mm		mm	mm	mm	mm	mm	mm	mm	Nm	Nm	kN	N/mm ²	N/mm ²	Stück	mm	kg	Nm
14	x	37	10	24	16	12	5	9	2,4	30	8	278	415	3	M4	0,1	37,5
			11							37	8		474				46
			12							48	10		557				60
16	x	41	12	27	20	15	6,25	12	4	70	15	336	509	4	M5	0,1	90
			13							90	18		575				110
			14							110	20		774				130
18	x	44	14	29	20	15	6,25	12	4	90	16	299	459	4	M5	0,2	110
			15							100	18		523				130
			16							120	20		705				160
20	x	46	15	32	22,5	17,5	7	12	4	110	20	336	462	5	M5	0,2	140
			16							140	22		497				170
			17							160	24		580				200
21	x	50	16	36	24	19	8	15	5	200	31	384	534	6	M5	0,2	250
			17							230	34		602				290
			18							260	37		746				330
24	x	50	19	36	24	19	8	15	5	240	32	336	495	6	M5	0,2	300
			20							270	35		554				340
			21							300	38		679				390
30	x	60	24	44	26,5	21,5	8,5	17	5	350	38	261	390	7	M5	0,2	450
			25							400	41		426				500
			26							440	43		492				560
36	x	72	28	52	29,5	23,5	10	18	12	590	53	303	390	5	M6	0,5	730
			30							690	58		438				860
			31							700	58		536				890

To continue see next page

Shrink Discs RINGFEDER® RfN 4061 stainless steel

Shrink Discs dimensions								Transmissible torques or axial forces		P	σ _v	High-strength special screws			T _{max}		
d	x	D	d _w	d ₁	L	L ₁	L ₂	L ₃	T _A			T	F _{ax}	ISO 4762		n _{Sc}	D _G
mm			mm	mm	mm	mm	mm	mm	Nm	Nm	kN	N/mm ²	N/mm ²	Stück	mm	kg	
38	x	72	29	55	32	26	10	21	12	700	62	295	378	6	M6	0,5	890
			30							770	65		394				970
			31							780	63		474				980
40	x	72	30	57	30,5	24,5	10,5	19	12	720	61	310	375	6	M6	0,5	900
			31							730	59		450				910
			32							790	62		460				990
44	x	80	32	63	32	26	11	20	12	800	63	312	429	7	M6	0,5	1000
			35							1000	73		444				1250
			36							1050	76		458				1350
48	x	80	36	68	32	26	11	22	12	900	65	260	371	7	M6	0,6	1150
			38							1050	72		380				1350
			40							1200	78		403				1550
50	x	90	38	70	33,5	27,5	11,5	22,5	12	1350	89	314	418	9	M6	0,9	1650
			40							1500	96		433				1900
			42							1700	103		467				2150
55	x	100	42	75	36,5	30,5	12	23	12	1300	78	248	343	8	M6	1,1	1600
			45							1550	87		359				1950
			48							1800	96		410				2300
62	x	110	48	86	36,5	30,5	12,5	23	12	2400	126	330	407	12	M6	1,3	3000
			50							2650	133		419				3300
			52							2800	136		482				3500
68	x	115	50	86	36,5	30,5	12	23,5	12	1900	95	245	314	10	M6	1,4	2350
			55							2250	104		367				2850
			60							2850	121		411				3600
75	x	138	55	100	40,5	32,5	13	25	30	2650	121	277	377	7	M8	2,3	3300
			60							3300	139		382				4150
			65							4050	158		416				5100
80	x	145	60	100	40,5	32,5	13	25	30	3200	126	259	353	7	M8	2,5	4000
			65							3900	143		358				4900
			70							4600	160		392				5750
85	x	155	60	114	48,5	40,5	16	30	30	4850	189	325	404	11	M8	3,5	6050
			65							5800	212		407				7250
			70							6800	235		427				8500
90	x	155	65	114	47	39	16	30	30	4800	174	274	353	10	M8	3,3	6000
			70							6050	195		356				7550
			75							7300	215		372				9150
95	x	170	65	127	55,1	47,1	19	34	30	5350	195	275	349	12	M8	4,7	6700
			70							6750	217		349				8450
			8150							240	355		10200				
100	x	170	6950	127	55,1	47,1	19	34	30	7600	223	261	331	12	M8	4,5	8700
			9100							245	338		11350				
			8150							259	316		10150				
110	x	185	75	145	63	53	21,5	42	59	10100	285	254	316	10	M10	6,3	12600
			12200							296	357		15250				
			9500							267	302		11850				
115	x	185	90	145	66	56	21,5	42	59	12100	302	243	342	10	M10	6,1	15100
			95							14050	329		353				17550

To continue see next page

Shrink Discs RINGFEDER® RfN 4061 stainless steel

Shrink Discs dimensions								Transmissible torques or axial forces		P	σ_v	High-strength special screws			T_{max}		
d	x	D	d _w	d ₁	L	L ₁	L ₂	L ₃	T _A			T	F _{ax}	σ_v		n _{Sc}	D _G
mm			mm	mm	mm	mm	mm	mm	Nm	Nm	kN	N/mm ²	N/mm ²	Stück	mm	kg	
125	x	215	85	160	64	54	23	42	59	11050	300	269	354	12	M10	8,7	13800
			90							13100	327		352				16350
			95							15150	355		352				18950
140	x	230	95	175	72,5	60,5	26	46	100	15100	365	263	336	10	M12	10,6	18850
			100							17550	395		335				21900
			105							20000	424		335				25000
165	x	290	115	210	87	71	31	56	250	31400	601	280	334	8	M16	21,7	39300
			120							35500	637		335				44400
			125							39400	664		348				49250
185	x	330	135	236	102,4	86,4	38,2	71	250	52500	786	246	307	10	M16	36	65600
			140							57350	828		310				71650
			145							62400	870		314				78000
195	x	350	140	246	102	86	38,2	71	250	65950	943	280	332	12	M16	40	82450
			150							77600	1035		338				97000
			155							83750	1081		345				104700
200	x	350	150	246	102	86	38,2	71	250	75000	1000	273	326	12	M16	39	93750
			155							81000	1045		330				101200
			160							87200	1091		337				109000

More sizes on request
To continue see next page

Shrink Discs RINGFEDER® RfN 4061 stainless steel

Explanation

d = Inner diameter	L₃ = Ringbreite	P = Hub surface pressure
D = Outer diameter	L₃ = Width of ring	σ_v = Equivalent stress in the hub
d_w = Solid shaft diameter	L_B = Width of the half Shrink Disc	n_{sc} = Quantity of screws
d₁ = Pitch circle diameter	T_A = Max tightened torque of the clamping screws	D_G = Thread
L₁ = Overall length (without screws)	T = Transmissible torque at given T _A	G_w = Weight
L₂ = Thrust ring width	F_{ax} = Transmissible axial force	T_{max} = Max. transmissible torque

Ordering example

Series	d	D	Version
RfN 4061	96	170	SST

SST = Stainless steel

Table Clearance

d _w		ISO	Max. clearance S mm
above	up to		
6	10	H6/j6	0,011
10	18		0,014
18	30		0,017
30	50	H6/h6	0,032
50	80	H6/g6	0,048
80	120	H7/g6	0,069
120	180		0,079
180	250		0,090
250	315		0,101
315	400		0,111
400	500		0,123
500	630		0,136
630	800		0,154

Technical information

- Surface finishes: For shaft R_a ≤ 3,2 μm
- Tolerances: For shaft see table
- When using a hollow shaft instead of a solid shaft please contact our Engineering-Team.
- Additional loads, e.g. tension, thrust or bending have to be taken into consideration accordingly
- Function values: The functional characteristics are valid with the screw tightening torque listed in the tables and the following assumed conditions: The locking screws are lubricated using MoS₂ (μ_{tot}= 0,1). The tapered cones are lubricated using MoS₂ (μ = 0,05). The contact surfaces (d_w) are in lightly oiled condition with coefficient of friction μ = 0,12. The hub and shaft materials have a modulus of elasticity of 210,000 N/mm². (Lower values result in increased values for T and F_{ax} with reduced tangential stress.) The maximum clearance S is being fully utilized. The shaft being used is solid, for hollow shaft applications the functional values will change. In cases where the assumed conditions do not apply then contact our Technical Department where we will be happy to assist you with your application.

Clearances considered for the calculation of the function values

Further information on
RINGFEDER® RfN 4061 stainless steel
 on www.ringfeder.com

Disclaimer of liability

All technical details and notes are non-binding and cannot be used as a basis for legal claims. The user is obligated to determine whether the represented products meet his requirements. We reserve the right carry out modifications at any time in the interests of technical progress.

Shrink Discs

RINGFEDER® RfN 4071

Standard series for high torque

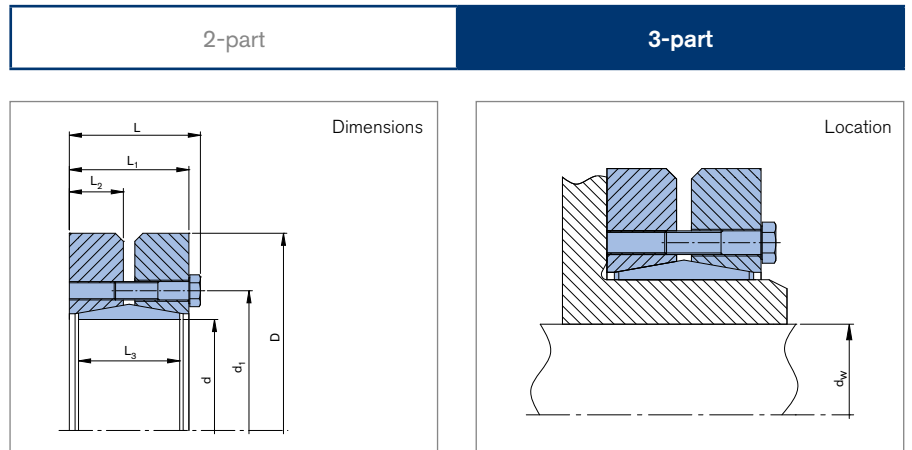

Shrink Discs dimensions											Transmissible torques or axial forces				Locking screws			
d	x	D	d _w	d ₁	L	L ₁	L ₂	L ₃	L _b	T _A	T	F _{ax}	P	σ _v	ISO 4014/4017 - 10.9			T _{max}
mm		mm	mm	mm	mm	mm	mm	mm	mm	Nm	Nm	kN	N/mm ²	N/mm ²	n _{sc}	D _G	G _w	T _{max}
															Stück	mm	kg	Nm
220	x	370	160	270	114	104	47	88	59,5	250	95000	1190	248	295	15	M16	54	118750
			165								102000	1239		298				127500
			170								110000	1290		303				137500
240	x	405	170	295	122	109	49	92	62	490	120000	1464	272	309	12	M20	67	150000
			180								138000	1576		315				172500
			190								156000	1675		334				195000
260	x	430	190	321	133	120	54	103	67,5	490	164000	1760	262	306	14	M20	82	205000
			200								184000	1880		314				230000
			210								205000	2010		329				256250
280	x	460	210	346	147	134	60	114	76,5	490	217000	2090	251	295	16	M20	102	271250
			220								244000	2220		306				305000
			230								270000	2350		324				337500
300	x	485	230	364	155	142	64	122	79,5	490	275000	2431	246	291	18	M20	118	343750
			240								295000	2567		303				368750
			245								315000	2636		312				393750
320	x	520	240	386	155	142	64	122	79,5	490	312000	2647	257	293	20	M20	131	390000
			250								340000	2786		301				425000
			260								374000	2900		320				467500
340	x	570	250	408	169	156	71	134	86,5	490	390000	3119	264	295	24	M20	186	487500
			260								422500	3249		307				528125
			270								460000	3400		317				575000
350	x	580	270	432	175	162	73	140	89,5	490	442000	3276	245	289	24	M20	195	552500
			280								480000	3430		300				600000
			285								500000	3500		307				625000

To continue see next page

Shrink Discs RINGFEDER® RfN 4071

Shrink Discs dimensions											Transmissible torques or axial forces				Locking screws			
d	x	D	d _w	d ₁	L	L ₁	L ₂	L ₃	L _B	T _A	T	F _{ax}	P	σ _v	ISO 4014/4017 - 10.9		G _w	T _{max}
mm			mm	mm	mm	mm	mm	mm	mm	Nm	Nm	kN	N/mm ²	N/mm ²	n _{Sc}	D _G	kg	Nm
360	x	590	280	432	175	162	73	140	89,5	490	463000	3310	238	282	24	M20	204	578750
			290								502000	3461		292				627500
			295								522000	3536		298				652500
380	x	645	290	458	183	168	76	144	92,5	840	567000	3910	263	300	20	M24	239	708750
			300								610000	4080		307				762500
			310								658000	4248		320				822500
390	x	660	300	468	183	168	76	144	92,5	840	624000	4160	270	305	21	M24	260	780000
			310								671000	4330		314				838750
			320								718000	4484		331				897500
400	x	680	315	480	183	168	76	144	92,5	840	670000	4260	263	302	21	M24	280	837500
			320								695000	4345		310				868750
			330								744000	4500		324				930000
420	x	690	330	504	203	188	86	164	106,5	840	780000	4850	251	295	24	M24	316	975000
			340								840000	5040		306				1050000
			350								900000	5220		322				1125000
440	x	750	340	527	217	202	91	177	113,5	840	806000	4740	223	267	24	M24	408	1007500
			350								860000	4910		274				1075000
			360								917000	5090		285				1146250
460	x	770	360	547	217	202	91	177	113,5	840	1000000	5670	248	293	28	M24	420	1250000
			370								1070000	5860		301				1337500
			380								1400000	6050		314				1750000
480	x	800	380	570	228	213	96	188	119	840	1170000	6150	240	282	30	M24	505	1462500
			390								1240000	6350		292				1550000
			400								1310000	6550		306				1637500
500	x	850	400	590	230	213	96	188	119	1250	1312000	6560	242	284	24	M27	575	1640000
			410								1380000	6730		297				1725000
			420								1455000	6930		311				1818750

More sizes on request
To continue see next page

Shrink Discs RINGFEDER® RfN 4071

Explanation

d = Inner diameter	L₂ = Thrust ring width	P = Hub surface pressure
D = Outer diameter	L₃ = Width of ring	σ_v = Equivalent stress in the hub
d_w = Solid shaft diameter	L_B = Width of the half Shrink Disc	n_{sc} = Quantity of screws
d₁ = Pitch circle diameter	T_A = Max tightened torque of the clamping screws	D_G = Thread
L = Overall length	T = Transmissible torque at given T _A	G_w = Weight
L₁ = Overall length (without screws)	F_{ax} = Transmissible axial force	T_{max} = Max. transmissible torque

Ordering example

Series	d	D
RfN 4071	420	520

Table Clearance

d _w		ISO	Max. clearance S mm
above	up to		
6	10	H6/j6	0,011
10	18		0,014
18	30		0,017
30	50	H6/h6	0,032
50	80	H6/g6	0,048
80	120	H7/g6	0,069
120	180		0,079
180	250		0,090
250	315		0,101
315	400		0,111
400	500		0,123
500	630		0,136
630	800	0,154	

Technical information

- Surface finishes: For shaft R_a ≤ 3,2 μm
- Tolerances: For shaft see table
- When using a hollow shaft instead of a solid shaft please contact our Engineering-Team.
- Additional loads, e.g. tension, thrust or bending have to be taken into consideration accordingly
- Function values: The functional characteristics are valid with the screw tightening torque listed in the tables and the following assumed conditions: The locking screws are lubricated using MoS₂ (μ_{tot} = 0,1). The tapered cones are lubricated using MoS₂ (μ = 0,05). The contact surfaces (d_w) are in lightly oiled condition with coefficient of friction μ = 0,12. The hub and shaft materials have a modulus of elasticity of 210,000 N/mm². (Lower values result in increased values for T and Fax with reduced tangential stress.) The maximum clearance S is being fully utilized. The shaft being used is solid, for hollow shaft applications the functional values will change. In cases where the assumed conditions do not apply then contact our Technical Department where we will be happy to assist you with your application.

Clearances considered for the calculation of the function values

Further information on
RINGFEDER® RfN 4071 on
www.ringfeder.com

Disclaimer of liability

All technical details and notes are non-binding and cannot be used as a basis for legal claims. The user is obligated to determine whether the represented products meet his requirements. We reserve the right carry out modifications at any time in the interests of technical progress.

Shrink Discs

RINGFEDER® RfN 4073

Mini series for particularly light applications

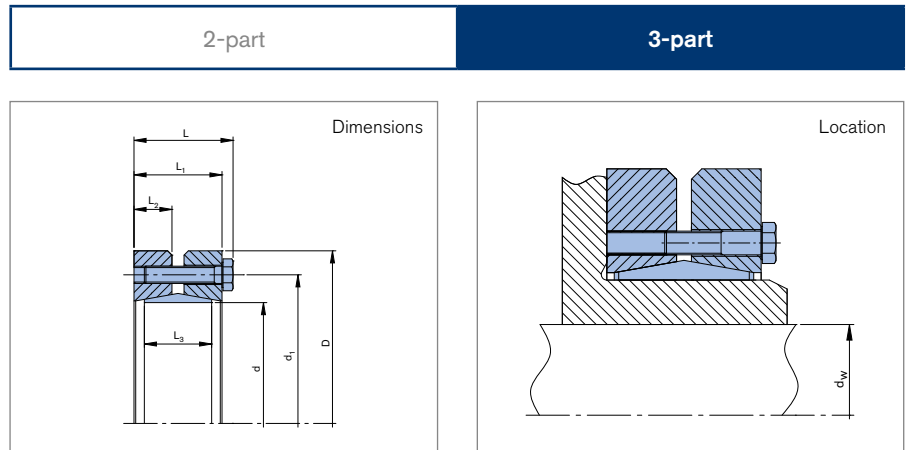

Shrink Discs dimensions										Transmissible torques or axial forces			Locking screws				
d	x	D	d _w	d ₁	L	L ₁	L ₂	L ₃	T _A	T	F _{ax}	P	σ _v	ISO 4014/4017 - 10.9			
mm			mm	mm	mm	mm	mm	mm	Nm	Nm	kN	N/mm ²	N/mm ²	n _{sc}	D _G	G _w	T _{max}
														Stück	mm	kg	Nm
14	x	34	9	24	14	12	5,0	9	2,4	9	2,5	222	389	3	M4 ^{*)}	0,1	18
			10							3,5	372		26				
			11							4,6	361		35				
16	x	42	11	30	14,8	12	5,0	9	2,4	32	7,2	264	408	4	M4 ^{*)}	0,1	40
			12							8,5	414		51				
			13							9,9	440		64				
20	x	47	14	34	17,5	14	6,0	10	3	41	7,3	193	310	4	M5	0,13	51
			15							8,4	311		64				
			16							9,6	320		78				
22	x	50	16	37	18,5	15	6,5	10	3	68	10,5	219	320	5	M5	0,16	85
			17							11,5	326		100				
			18							13,0	341		118				
24	x	50	18	39	18,5	15	6,5	10	5	185	26,0	274	503	5	M5	0,16	231
			19							28,0	543		256				
			20							30,0	581		293				
28	x	56	20	43	18,5	15	6,5	10	3	77	9,6	172	270	5	M5	0,18	96
			22							11,5	271		129				
			24							13,5	289		165				
31	x	60	24	46	18,5	15	6,5	10	3	110	11,0	156	244	5	M5	0,2	138
			25							12,0	246		154				
			27							14,0	264		193				
36	x	66	28	52	18,5	15	6,5	10	3	161	14,0	161	233	6	M5	0,24	201
			30							16,0	239		243				
			32							16,5	328		269				

^{*)} Different quality of screws. ISO 4014/4017 - 8.8

To continue see next page

Shrink Discs RINGFEDER® RfN 4073

Shrink Discs dimensions										Transmissible torques or axial forces			Locking screws				
d	x	D	d _w	d ₁	L	L ₁	L ₂	L ₃	T _A	T	F _{ax}	P	σ _v	ISO 4014/4017 - 10.9			
mm			mm	mm	mm	mm	mm	mm	Nm	Nm	kN	N/mm ²	N/mm ²	n _{Sc}	D _G	G _w	T _{max}
														Stück	mm	kg	Nm
40	x	68	33	55	18,5	15	6,5	10	4	265	20,0	194	325	6	M5	0,23	331
			34							290			329				363
			35							320			336				396
46	x	80	38	63	22,5	19	8,0	14	4	400	26,0	160	278	8	M5	0,44	503
			40							470			288				589
			42							550			326				683
51	x	86	42	68,5	22,5	19	8,0	14	4	440	26,0	144	249	8	M5	0,49	550
			44							510			255				640
			45							550			261				680
56	x	91	46	73	22,5	19	8,0	14	4	560	30,0	148	241	9	M5	0,52	690
			48							630			245				790
			50							710			258				890
61	x	96	52	77	22,5	19	8,0	14	4	710	34,0	151	285	10	M5	0,56	890
			54							810			291				1010
			56							910			309				1130
66	x	100	58	82	22,5	19	8,0	14	4	850	36,5	140	266	10	M5	0,57	1070
			60							950			276				1190
			62							1060			308				1320
70	x	110	62	90	27,5	24	10,0	18	6	1410	56,5	153	279	10	M5	0,93	1770
			64							1560			300				1950
			65							1630			322				2040
75	x	114	66	93	27,5	24	10,0	18	6	1480	55,0	142	256	10	M5	0,93	1840
			68							1620			268				2020
			70							1770			301				2210
80	x	120	71	101	27,5	24	10,0	18	6	2000	70,0	161	269	12	M5	1,04	2500
			73							2160			285				2700
			75							2330			329				2920
85	x	128	76	105	32	28	11,5	22	12	2370	77,5	137	246	8	M6	1,41	2960
			78							2560			266				3200
			80							2760			316				3450
94	x	140	82	119	32	28	11,5	22	12	2300	69,5	124	253	8	M6	1,66	2870
			85							2600			262				3250
			88							2920			289				3660
105	x	150	92	128	32	28	11,5	22	12	3000	81,0	125	239	9	M6	1,77	3750
			95							3330			246				4160
			98							3680			266				4600
112	x	158	100	135	32	28	11,5	22	12	3390	84,5	117	225	9	M6	1,91	4240
			104							3850			241				3570
			106							4100			264				5120
120	x	164	106	141	36	32	13,0	25	12	3900	91,5	107	208	10	M6	2,2	4870
			110							4400			217				5500
			112							4670			230				5830
130	x	172	115	151	36	32	13,0	25	12	4250	99,0	99	191	10	M6	2,21	5320
			120							4890			202				6110
			122							5100			225				6380
140	x	182	125	161	36	32	13,0	25	12	5690	135,0	110	208	12	M6	2,4	7110
			128							6140			213				7670
			130							6450			220				8060

To continue see next page

Shrink Discs RINGFEDER® RfN 4073

Shrink Discs dimensions										Transmissible torques or axial forces				Locking screws			
d	x	D	d _w	d ₁	L	L ₁	L ₂	L ₃	T _A	T	F _{ax}	P	σ _v	n _{Sc}	D _G	G _w	T _{max}
mm			mm	mm	mm	mm	mm	mm	Nm	Nm	kN	N/mm ²	N/mm ²	Stück	mm	kg	Nm
150	x	194	135	171	36	32	13,0	25	12	6280	116,0	103	194	12	M6	2,7	7840
			138							6730	121,0		200				8420
			140							7050	125,0		206				8810
160	x	204	142	181	36	32	13,0	25	12	6360	111,0	96	179	12	M6	2,8	7940
			145							6800	117,0		182				8500
			148							7260	122,0		187				9070

More sizes on request
To continue see next page

Shrink Discs RINGFEDER® RfN 4073

Explanation

d = Inner diameter	L₂ = Thrust ring width	P = Hub surface pressure
D = Outer diameter	L₃ = Width of ring	σ_v = Equivalent stress in the hub
d_w = Solid shaft diameter	L_B = Width of the half Shrink Disc	n_{sc} = Quantity of screws
d₁ = Pitch circle diameter	T_A = Max tightened torque of the clamping screws	D_G = Thread
L = Overall length	T = Transmissible torque at given T _A	G_w = Weight
L₁ = Overall length (without screws)	F_{ax} = Transmissible axial force	T_{max} = Max. transmissible torque

Ordering example

Series	d	D
RfN 4073	46	80

Table Clearance

d _w		ISO	Max. clearance S mm
above	up to		
6	10	H6/j6	0,011
10	18		0,014
18	30		0,017
30	50	H6/h6	0,032
50	80	H6/g6	0,048
80	120	H7/g6	0,069
120	180		0,079
180	250		0,090
250	315		0,101
315	400		0,111
400	500		0,123
500	630		0,136
630	800		0,154

Technical information

- Surface finishes: For shaft R_a ≤ 3,2 μm
- Tolerances: For shaft see table
- When using a hollow shaft instead of a solid shaft please contact our Engineering-Team.
- Additional loads, e.g. tension, thrust or bending have to be taken into consideration accordingly
- Function values: The functional characteristics are valid with the screw tightening torque listed in the tables and the following assumed conditions: The locking screws are lubricated using MoS₂ (μ_{tot} = 0,1). The tapered cones are lubricated using MoS₂ (μ = 0,05). The contact surfaces (d_w) are in lightly oiled condition with coefficient of friction μ = 0,12. The hub and shaft materials have a modulus of elasticity of 210,000 N/mm². (Lower values result in increased values for T and Fax with reduced tangential stress.) The maximum clearance S is being fully utilized. The shaft being used is solid, for hollow shaft applications the functional values will change. In cases where the assumed conditions do not apply then contact our Technical Department where we will be happy to assist you with your application.

Clearances considered for the calculation of the function values

Further information on
RINGFEDER® RfN 4073 on
www.ringfeder.com

Disclaimer of liability

All technical details and notes are non-binding and cannot be used as a basis for legal claims. The user is obligated to determine whether the represented products meet his requirements. We reserve the right carry out modifications at any time in the interests of technical progress.

Shrink Discs

RINGFEDER® RfN 4091

Heavy series for the highest torque

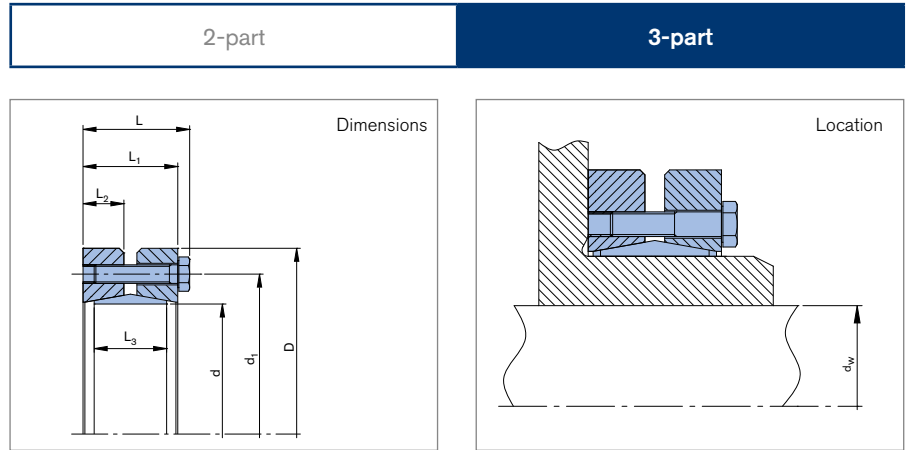

Shrink Discs dimensions											Transmissible torques or axial forces				Locking screws			
d	x	D	d _w	d ₁	L	L ₁	L ₂	L ₃	L _B	T _A	T	F _{ax}	P	σ _v	ISO 4014/4017 - 10.9			T _{max}
mm			mm	mm	mm	mm	mm	mm	mm	Nm	Nm	kN	N/mm ²	N/mm ²	n _{Sc}	D _G	G _w	Nm
															Stück	mm	kg	
50	x	95	38	73	44,5	39	17	30	23	25	1800	106	285	410	7	M8	1,4	2250
			2100								115	447		2625				
			2400								124	511		3000				
55	x	105	42	78	44,5	39	17	30	23	28	2250	122	290	404	7	M8	1,7	2813
			2700								135	457		3375				
			3200								148	574		4000				
62	x	115	48	85	44,5	39	17	30	23	30	2950	134	276	376	7	M8	2	3688
			3400								142	401		4250				
			3600								145	458		4500				
68	x	118	50	93	49	44	19	34	27	30	3600	147	260	334	8	M8	2,1	4500
			4600								168	362		5750				
			5700								190	475		7125				
75	x	145	55	105	53	46	20	36	27	59	4600	193	302	403	7	M10	3,8	5750
			5700								221	437		7125				
			7000								249	540		8750				
80	x	145	60	105	53	46	20	36	27	59	5700	200	283	379	7	M10	3,6	7125
			7000								226	413		8750				
			8400								253	510		10500				
90	x	160	65	116	57	50	22	40	29	59	6700	217	259	339	8	M10	4,8	8375
			8100								243	352		10125				
			9600								269	395		12000				
100	x	170	70	126	61	54	23	44	32	59	8800	265	265	334	10	M10	5,6	11000
			10000								293	342		12500				
			12200								321	368		15250				

To continue see next page

Shrink Discs RINGFEDER® RfN 4091

Shrink Discs dimensions										Transmissible torques or axial forces				Locking screws				
d	x	D	d _w	d ₁	L	L ₁	L ₂	L ₃	L _B	T _A	T	F _{ax}	P	σ _v	ISO 4014/4017 - 10.9			T _{max}
mm			mm	mm	mm	mm	mm	mm	mm	Nm	Nm	kN	N/mm ²	N/mm ²	n _{Sc}	D _G	G _w	T _{max}
															Stück	mm	kg	Nm
110	x	185	75	138	67	60	26	50	35	59	11000	308	254	316	12	M10	7,6	13750
			80								12900	338						16125
			85								14700	352						18375
125	x	215	85	160	73	65	28	55	37,5	100	15000	355	248	331	10	M12	11	18750
			90								17500	388						21875
			95								20000	422						25000
135	x	212	90	172	85	77	32	60	45	100	18800	420	251	330	12	M12	10,7	22500
			95								21600	456						27000
			105								27800	531						34750
140	x	300	90	220	106	96	42	80	54	250	36700	817	360	423	12	M16	35,5	45850
			100								47000	942						58750
			110								58700	1096						73350
155	x	263	105	197	91,5	84	35	66	45	100	28900	551	248	310	15	M12	19,6	36100
			110								32400	590						40500
			115								36200	630						45250
165	x	290	115	210	98	88	38	72	49	250	41000	740	270	324	10	M16	26	51250
			120								46000	785						57500
			125								50700	815						63375
175	x	300	125	220	124	114	50	92	59	250	72800	1165	301	367	15	M16	36,5	91000
			130								79900	1230						99850
			135								87300	1294						109100
185	x	330	135	236	122	112	50	92	61	250	72000	1100	263	327	14	M16	47	90000
			140								78000	1150						97500
			145								86000	1200						107500
190	x	350	135	239	129	116,5	50	92	62	470	95100	1409	331	386	12	M20	55	118850
			140								103400	1478						129250
			155								130600	1685						163250
195	x	350	140	246	122	112	50	92	63,5	250	75000	1075	250	310	14	M16	53	93750
			150								88000	1180						110000
			155								96000	1235						120000
200	x	350	145	246	122	112	50	92	63,5	250	85000	1170	261	317	15	M16	50	106250
			150								92500	1230						115625
			155								100000	1290						125000
220	x	370	160	270	144	134	60	114	74,5	250	127000	1590	255	309	20	M16	65	158750
			165								136000	1650						170000
			170								146500	1720						183125
240	x	405	170	295	157	144	65	120	79,5	490	155000	1820	261	305	15	M20	87	193750
			180								176000	1960						220000
			190								198000	2080						247500
260	x	430	190	321	173	160	72	136	87,5	490	213000	2260	255	308	18	M20	100	266250
			200								240000	2420						300000
			210								268000	2580						335000
280	x	460	210	346	185	172	78	148	96	490	285000	2740	254	310	21	M20	132	356250
			220								320000	2910						400000
			230								355000	3090						443750
300	x	485	230	364	189	176	80	152	98	490	341000	2960	242	298	22	M20	140	426250
			240								376000	3130						470000
			245								394000	3215						492500

To continue see next page

Shrink Discs RINGFEDER® RfN 4091

Shrink Discs dimensions										Transmissible torques or axial forces				Locking screws				
d	x	D	d _w	d ₁	L	L ₁	L ₂	L ₃	L _B	T _A	T	F _{ax}	P	σ _v	ISO 4014/4017 - 10.9			T _{max}
mm			mm	mm	mm	mm	mm	mm	mm	Nm	Nm	kN	N/mm ²	N/mm ²	n _{Sc}	D _G	G _w	T _{max}
															Stück	mm	kg	Nm
320	x	520	240	386	196,5	184	82	160	102	490	378000	3150	235	282	24	M20	165	472500
			250								415000	3325						518750
			260								451000	3470						563750
340	x	570	250	420	215	200	92	176	110	840	489500	3910	253	295	21	M24	240	611875
			260								530000	4075						662500
			270								578000	4275						722500
350	x	580	270	425	215	200	92	176	110	840	556000	4122	247	304	21	M24	247	695000
			280								604000	4320						755000
			285								629000	4415						786250
360	x	590	280	432	219	204	92	180	114,5	840	612000	4370	245	303	22	M24	250	765000
			290								663000	4570						828750
			295								689000	4670						861250
380	x	645	290	458	219	204	92	180	114,5	840	618000	4270	233	279	22	M24	320	772500
			300								668000	4455						835000
			310								719000	4645						898750
390	x	660	300	468	227	212	96	188	118,5	840	708000	4715	236	284	24	M24	350	885000
			310								762000	4910						952500
			320								814500	5090						1018125
400	x	680	315	480	227	212	96	188	118,5	840	765000	4855	231	285	24	M24	370	956250
			320								788000	4927						985000
			330								845000	5125						1056250
420	x	690	330	504	253	238	111	214	131,5	840	999000	6055	241	302	30	M24	410	1248750
			340								1068000	6285						1335000
			350								1140000	6515						1425000
440	x	750	340	527	269	252	115	224	138,5	1250	1058000	6230	231	283	24	M27	540	1322500
			350								1130000	6460						1412500
			360								1204000	6690						1505000
460	x	770	360	547	269	252	115	224	141	1250	1320000	7440	257	312	28	M27	540	1650000
			370								1420000	7700						1775000
			380								1500000	7950						1875000
480	x	800	380	580	291	274	128	246	152	1250	1535000	8080	241	302	30	M27	650	1918750
			390								1626000	8340						2032500
			400								1720000	8600						2150000
500	x	850	400	600	291	274	128	246	152	1250	1750000	8750	246	309	32	M27	750	2187500
			410								1840000	8980						2300000
			420								1940000	9250						2425000

More sizes on request
To continue see next page

Shrink Discs RINGFEDER® RfN 4091

Explanation

d = Inner diameter	L₂ = Thrust ring width	P = Hub surface pressure
D = Outer diameter	L₃ = Width of ring	σ_v = Equivalent stress in the hub
d_w = Solid shaft diameter	L_B = Width of the half Shrink Disc	n_{sc} = Quantity of screws
d₁ = Pitch circle diameter	T_A = Max tightened torque of the clamping screws	D_G = Thread
L = Overall length	T = Transmissible torque at given T _A	G_w = Weight
L₁ = Overall length (without screws)	F_{ax} = Transmissible axial force	T_{max} = Max. transmissible torque

Ordering example

Series	d	D
RfN 4091	100	170

Table Clearance

d _w		ISO	Max. clearance S mm
above	up to		
6	10	H6/j6	0,011
10	18		0,014
18	30		0,017
30	50	H6/h6	0,032
50	80	H6/g6	0,048
80	120	H7/g6	0,069
120	180		0,079
180	250		0,090
250	315		0,101
315	400		0,111
400	500		0,123
500	630		0,136
630	800	0,154	

Technical information

- Surface finishes: For shaft R_a ≤ 3,2 μm
- Tolerances: For shaft see table
- When using a hollow shaft instead of a solid shaft please contact our Engineering-Team.
- Additional loads, e.g. tension, thrust or bending have to be taken into consideration accordingly
- Function values: The functional characteristics are valid with the screw tightening torque listed in the tables and the following assumed conditions: The locking screws are lubricated using MoS₂ (μ_{tot} = 0,1). The tapered cones are lubricated using MoS₂ (μ = 0,05). The contact surfaces (d_w) are in lightly oiled condition with coefficient of friction μ = 0,12. The hub and shaft materials have a modulus of elasticity of 210,000 N/mm². (Lower values result in increased values for T and Fax with reduced tangential stress.) The maximum clearance S is being fully utilized. The shaft being used is solid, for hollow shaft applications the functional values will change. In cases where the assumed conditions do not apply then contact our Technical Department where we will be happy to assist you with your application.

Clearances considered for the calculation of the function values

Further information on
RINGFEDER® RfN 4091 on
www.ringfeder.com

Disclaimer of liability

All technical details and notes are non-binding and cannot be used as a basis for legal claims. The user is obligated to determine whether the represented products meet his requirements. We reserve the right carry out modifications at any time in the interests of technical progress.

Shrink Discs

RINGFEDER® RfN 4161

Standard series for high torque

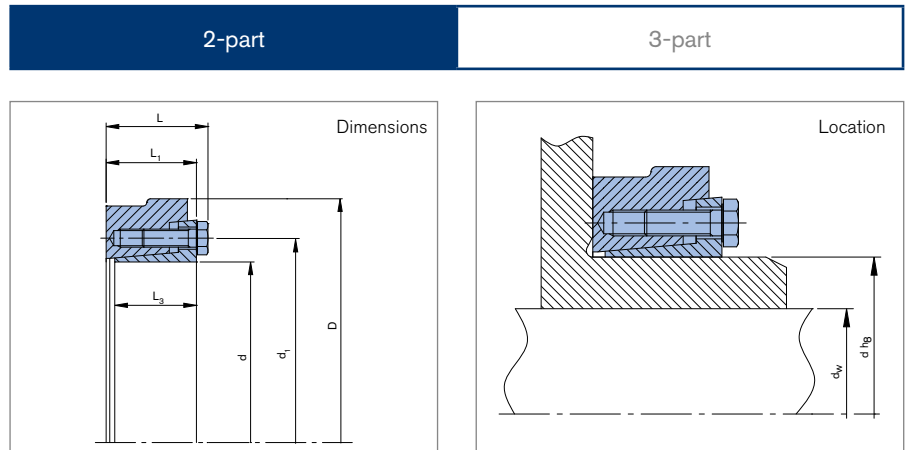

Shrink Discs dimensions							Transmissible torques or axial forces			Locking screws ISO 4014/4017 - 12.9			
d	x	D	d _w	d ₁	L	L ₁	L ₃	T _A	T	F _{ax}	D _G	G _w	T _{max}
mm			mm	mm	mm	mm	mm	Nm	Nm	kN	mm	kg	Nm
18	x	44	15	30	19	15	13	12	80	11	M6	0,15	88
			16						110	14			121
			---						---	---			---
20	x	47	17	32	19,3	15,3	13,5	12	150	18	M6	0,2	165
			18						180	20			198
			---						---	---			---
24	x	50	19	36	22	18	15	12	160	17	M6	0,2	176
			20						210	20			231
			22						280	25			308
26	x	51,5	20	38	22	18	16	12	230	23	M6	0,2	253
			22						300	27			330
			24						310	29			341
30	x	60	24	44	24	20	17	12	270	23	M6	0,3	297
			25						320	25			352
			26						360	28			396
36	x	72	27	52	27,3	22	18,5	35	510	37	M8	0,5	561
			30						710	47			781
			33						950	58			1045
38	x	72	27	54	27,3	22	18,5	35	480	36	M8	0,5	528
			30						650	43			715
			33						860	52			946
40	x	80	34	61	29,3	24	20,5	35	810	48	M8	0,7	891
			35						880	50			968
			37						960	52			1056

To continue see next page

Shrink Discs RINGFEDER® RfN 4161

Shrink Discs dimensions								Transmissible torques or axial forces		Locking screws ISO 4014/4017 - 12.9			
d	x	D	d _w	d ₁	L	L ₁	L ₃	T _A	T	F _{ax}	D _G	G _w	T _{max}
mm			mm	mm	mm	mm	mm	Nm	Nm	kN	mm	kg	Nm
44	x	80	35	61	29,3	24	20,5	35	800	52	M8	0,6	880
			36						890	57			979
			37						1050	60			1155
50	x	90	38	68	31,3	26	22	35	1500	79	M8	0,8	1650
			40						1700	87			1870
			42						2000	94			2200
55	x	100	42	72	34,3	29	25	35	1600	78	M8	1,1	1760
			45						2000	88			2200
			48						2400	99			2640
60	x	110	48	80	34,3	29	24,5	35	2200	92	M8	1,3	2420
			50						2500	98			2750
			52						2700	105			2970
62	x	110	48	80	34,3	29	24,5	35	2200	92	M8	1,3	2420
			50						2500	98			2750
			52						2700	105			2970
68	x	115	50	86	34,3	29	24,5	35	2400	94	M8	1,4	2640
			55						3000	111			3300
			60						3800	128			4180
75	x	138	55	100	37,5	31	26,3	70	3700	135	M10	2,3	4070
			60						4700	156			5170
			65						5800	177			6380
80	x	141	60	104	37,5	31	26	70	4200	141	M10	2,3	4620
			65						5200	160			5720
			70						6300	180			6930
85	x	155	65	114	45	38	34	70	5900	186	M10	3,7	6490
			70						7200	204			7920
			75						8500	227			9350
90	x	155	65	114	45	38	33	70	5900	182	M10	3,5	6490
			70						7200	204			7920
			75						8500	227			9350
95	x	170	70	124	49,5	43	37,5	70	7400	213	M10	4,9	8140
			75						8900	236			9790
			80						10400	260			11440
100	x	185	80	139	56,5	49	43	121	15000	370	M12	6,7	16500
			85						17300	400			19030
			90						19600	430			21560
105	x	185	80	139	56,5	49	43	121	13900	348	M12	6,4	15290
			85						16100	380			17710
			90						18600	434			20460
110	x	185	80	139	56,5	49	43	121	15500	380	M12	6,1	17050
			85						17800	410			19580
			90						20000	440			22000
115	x	200	85	150	62,5	55	48	121	17200	405	M12	8	18920
			90						19900	443			21890
			95						22900	482			25190
120	x	200	85	150	62,5	55	48	121	17300	405	M12	7,7	18920
			90						19900	443			21890
			95						22900	482			25190

To continue see next page

Shrink Discs RINGFEDER® RfN 4161

Shrink Discs dimensions								T _A	Transmissible torques or axial forces		Locking screws		T _{max}
d	x	D	d _w	d ₁	L	L ₁	L ₃		T	F _{ax}	ISO 4014/4017 - 12.9	G _w	
mm			mm	mm	mm	mm	mm	Nm	Nm	kN	mm	kg	Nm
125	x	215	90	157	60,5	53	46,5	121	19200	420	M12	9	21120
			95						21700	450			23870
			100						24400	480			26840
130	x	230	95	172	65,5	58	51	121	25900	540	M12	11,5	28490
			100						29000	580			31900
			110						36000	650			38600
135	x	230	95	172	67	58	51	190	21450	452	M14	11,1	23595
			100						24300	486			26730
			110						30500	555			33500
140	x	230	100	172	67	58	51	190	25300	500	M14	10,7	27830
			105						28000	530			30800
			115						35600	610			39160
150	x	263	110	190	71	62	55	190	37000	673	M14	16,3	40700
			120						45300	754			49830
			125						49700	795			54670
155	x	263	110	190	71	62	55	190	33000	600	M14	15,8	36300
			115						36600	637			40260
			120						40500	674			44550
160	x	290	120	200	78	68	61	290	57300	950	M16	22,3	63030
			130						66700	1020			73370
			135						72500	1070			79750
165	x	290	120	200	78	68	61	290	56500	940	M16	21,7	62150
			125						61500	980			67650
			135						72500	1070			79750
170	x	300	130	210	78,5	68,5	61	290	61000	938	M16	22,3	67100
			140						72300	1023			79530
			145						78400	1081			86240
175	x	300	130	210	78,5	68,5	61	290	61500	900	M16	21,7	67650
			135						67000	990			73700
			140						72500	1030			79750
180	x	320	140	224	97	87	77,5	290	86500	1237	M16	34	95150
			150						101400	1352			111540
			155						109300	1401			120230
185	x	320	140	224	97	87	77,5	290	96000	1250	M16	33,1	105600
			145						104000	1350			114400
			155						120000	1550			132000
190	x	320	150	238	96	86	76	290	92000	1250	M16	32	101200
			155						99000	1300			108900
			165						113500	1400			124850
195	x	340	150	238	95,5	85,5	77	290	103000	1374	M16	35	113300
			160						119300	1491			131230
			165						126100	1529			138710
200	x	340	150	238	95,5	85,5	77	290	108000	1450	M16	34	118800
			155						116000	1500			127600
			160						124000	1550			136400

More sizes on request
To continue see next page

Shrink Discs RINGFEDER® RfN 4161

Explanation

d = Inner diameter	L₁ = Overall length (without screws)	n_{Sc} = Quantity of screws
D = Outer diameter	L₃ = Width of ring	D_G = Thread
d_w = Solid shaft diameter	T_A = Max tightened torque of the clamping screws	G_w = Weight
d₁ = Pitch circle diameter	T = Transmissible torque at given T _A	T_{max} = Max. transmissible torque
L = Overall length	F_{ax} = Transmissible axial force	

Ordering example

Series	d	D
RfN 4161	150	263

Table Clearance

d _w		ISO	Max. clearance S mm
above	up to		
6	10	H6/j6	0,011
10	18		0,014
18	30		0,017
30	50	H6/h6	0,032
50	80	H6/g6	0,048
80	120	H7/g6	0,069
120	180		0,079
180	250		0,090
250	315		0,101
315	400		0,111
400	500		0,123
500	630		0,136
630	800		0,154

Clearances considered for the calculation of the function values

Technical information

- Surface finishes: For shaft R_a ≤ 3,2 μm
- Tolerances: For shaft see table
- When using a hollow shaft instead of a solid shaft please contact our Engineering-Team.
- Hub with yield strength R_{p0,2} ≥ 360 N/mm²
- Additional loads, e.g. tension, thrust or bending have to be taken into consideration accordingly
- Function values: The functional characteristics are valid with the screw tightening torque listed in the tables and the following assumed conditions: The locking screws are lubricated using MoS₂ (μ_{tot} = 0,1). The tapered cones are lubricated using MoS₂ (μ = 0,05). The contact surfaces (d_w) are in lightly oiled condition with coefficient of friction μ = 0,12. The hub and shaft materials have a modulus of elasticity of 210,000 N/mm². (Lower values result in increased values for T and Fax with reduced tangential stress.) The maximum clearance S is being fully utilized. The shaft being used is solid, for hollow shaft applications the functional values will change. In cases where the assumed conditions do not apply then contact our Technical Department where we will be happy to assist you with your application.

Further information on
RINGFEDER® RfN 4161 on
www.ringfeder.com

Disclaimer of liability

All technical details and notes are non-binding and cannot be used as a basis for legal claims. The user is obligated to determine whether the represented products meet his requirements. We reserve the right carry out modifications at any time in the interests of technical progress.

Shrink Discs

RINGFEDER® RfN 4181

Standard series for the highest torque

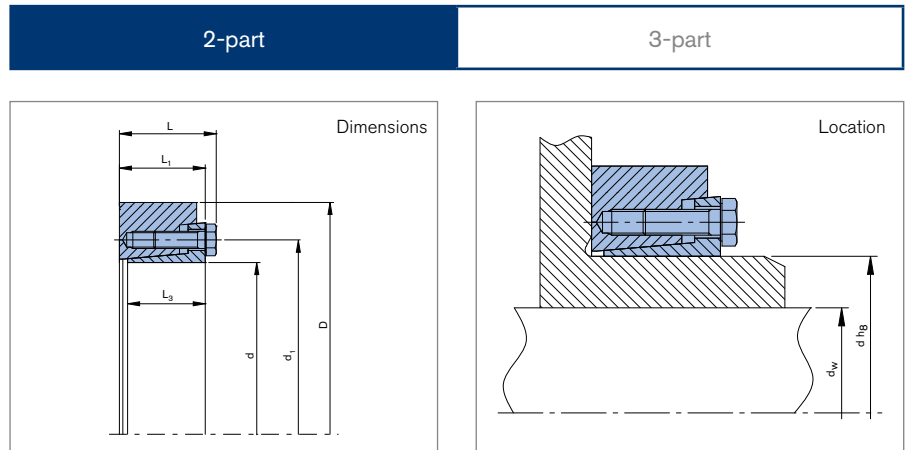

Shrink Discs dimensions							Transmissible torques or axial forces			Locking screws			
d	x	D	d _w	d ₁	L	L ₁	L ₃	T _A	T	F _{ax}	ISO 4014/4017 - 12.9		
mm			mm	mm	mm	mm	mm	Nm	Nm	kN	D _G	G _w	T _{max}
											mm	kg	Nm
220	x	370	160	270	115,8	103,3	87	570	160000	2000	M20	52,11	176000
			170						182000	2150			200200
			180						206000	2300			226600
240	x	405	170	296	121,4	108,9	92	570	190000	2250	M20	66,58	209000
			180						215000	2400			236500
			200						269000	2700			295900
260	x	430	190	318	128,4	115,9	102	580	247000	2600	M20	77,29	271700
			200						277000	2750			304700
			220						340000	3100			374000
280	x	460	210	340	146,4	133,9	121	570	282000	2686	M20	103,28	310200
			220						313000	2845			344300
			240						380000	3167			418000
300	x	485	220	360	154,1	139,1	122	980	385000	3500	M24	117,05	423500
			230						425000	3700			467500
			250						505000	4050			555500
320	x	520	240	380	156,6	141,6	124	980	444000	3700	M24	132,1	488400
			250						488000	3904			536800
			270						580000	4296			638000
340	x	570	250	402	167,5	152,5	135	980	564000	4500	M24	184,25	620400
			260						612000	4700			673200
			270						668000	4950			734800
360	x	590	270	424	182,7	167,7	150	980	658000	4850	M24	208,11	723800
			280						712000	5100			783200
			300						825000	5500			907500

To continue see next page

Shrink Discs RINGFEDER® RfN 4181

Shrink Discs dimensions							T _A	Transmissible torques or axial forces		Locking screws		T _{max}	
d	x	D	d _w	d ₁	L	L ₁		L ₃	T	F _{ax}	ISO 4014/4017 - 12.9		G _w
mm			mm	mm	mm	mm	mm	Nm	Nm	kN	mm	kg	
380	x	640	290	444	185,1	168,1	148	1450	735000	5069	M27	247,5	808500
			300						790000	5266			869000
			310						845000	5452			929500
390	x	650	290	470	186,3	167,6	144	1900	903000	6250	M30	259,55	993300
			300						970000	6450			1067000
			320						1101000	6950			1221000
420	x	670	320	495	203,9	186,9	166	1450	969000	6056	M27	284,75	1065900
			330						1038000	6291			1141800
			350						1183000	6762			1301300
440	x	740	340	518	212,9	195,9	178	1450	1212000	7129	M27	398	1333200
			350						1292000	7383			1421200
			370						1460000	7892			1606000
480	x	790	380	552	243,7	225,0	201	1900	1815000	9552	M30	495,4	1996500
			390						1920000	9845			2112000
			410						2118000	10331			2329800
500	x	835	400	572	238,7	220,0	198	1900	2054000	10270	M30	626,3	2259400
			410						2145000	10463			2359500
			430						2377000	11055			2614700
530	x	850	430	608	260,0	240,0	206	1900	2397000	11150	M30	653,4	2636700
			440						2520520	11457			2772572
			460						2777417	12076			3055159
560	x	940	450	632	260,0	240,0	206	1900	2545000	11311	M30	748,7	2799500
			460						2670006	11609			2937006
			480						2929521	12206			3222473
590	x	960	470	654	380,0	361,0	286	1900	4012000	17072	M30	1173,9	4413200
			480						4199188	17497			4619106
			500						4587043	18348			5045747
620	x	970	500	720	304,0	285,0	244	1900	3402000	13608	M30	886,7	3742200
			520						3708000	14261			4078800
			540						4028000	14918			4430800
660	x	1040	530	728	418,0	396,0	310	3500	5758000	21750	M36	1448,2	6333800
			550						6236900	22680			6860590
			570						6735919	23635			7409510
700	x	1140	560	815	315,0	294,0	260	2700	4518700	16138	M33	1467,5	4970570
			580						4880000	16828			5368000
			600						5258000	17527			5783800
750	x	1150	600	900	340,0	428,0	360	3500	7669000	25563	M36	1847,5	8435900
			620						8228643	26544			9051507
			650						9106895	28021			10017584
800	x	1230	640	935	373,0	352,0	296	2700	6897960	21226	M33	1894,4	7587756
			660						7378000	22358			8115800
			700						8390500	23973			9229550

To continue see next page

Shrink Discs RINGFEDER® RfN 4181

Explanation

d = Inner diameter	L₁ = Overall length (without screws)	n_{Sc} = Quantity of screws
D = Outer diameter	L₃ = Width of ring	D_G = Thread
d_w = Solid shaft diameter	T_A = Max tightened torque of the clamping screws	G_w = Weight
d₁ = Pitch circle diameter	T = Transmissible torque at given T _A	T_{max} = Max. transmissible torque
L = Overall length	F_{ax} = Transmissible axial force	

Ordering example

Series	d	D
RfN 4181	260	430

Table Clearance

d _w		ISO	Max. clearance S mm
above	up to		
6	10	H6/j6	0,011
10	18		0,014
18	30		0,017
30	50	H6/h6	0,032
50	80	H6/g6	0,048
80	120	H7/g6	0,069
120	180		0,079
180	250		0,090
250	315		0,101
315	400		0,111
400	500		0,123
500	630		0,136
630	800		0,154

Clearances considered for the calculation of the function values

Technical information

- Surface finishes: For shaft R_a ≤ 3,2 μm
- Tolerances: For shaft see table
- When using a hollow shaft instead of a solid shaft please contact our Engineering-Team.
- Hub with yield strength Rp0,2 ≥ 360 N/mm²
- Additional loads, e.g. tension, thrust or bending have to be taken into consideration accordingly
- Function values: The functional characteristics are valid with the screw tightening torque listed in the tables and the following assumed conditions: The locking screws are lubricated using MoS₂ (μ_{tot} = 0,1). The tapered cones are lubricated using MoS₂ (μ = 0,05). The contact surfaces (d_w) are in lightly oiled condition with coefficient of friction μ = 0,12. The hub and shaft materials have a modulus of elasticity of 210,000 N/mm². (Lower values result in increased values for T and Fax with reduced tangential stress.) The maximum clearance S is being fully utilized. The shaft being used is solid, for hollow shaft applications the functional values will change. In cases where the assumed conditions do not apply then contact our Technical Department where we will be happy to assist you with your application.

Further information on
RINGFEDER® RfN 4181 on
www.ringfeder.com

Disclaimer of liability

All technical details and notes are non-binding and cannot be used as a basis for legal claims. The user is obligated to determine whether the represented products meet his requirements. We reserve the right carry out modifications at any time in the interests of technical progress.