

# Torsional Highflex Couplings

## RINGFEDER® TNR 2424.1

### Single-row, SAE flange-shaft connections

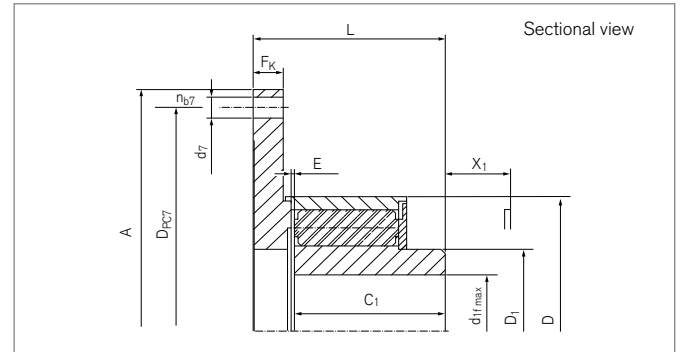

Size	d <sub>1f max</sub>	SAE size	A	D <sub>PC7</sub>	d <sub>7</sub>	n <sub>b7</sub>	D	D <sub>1</sub>	C <sub>1</sub>
			mm	mm	mm		mm	mm	mm
120.1 - 06.5	50	6,5	215,9	200,0	9,5	6	120	73	65
120.1 - 07.5	50	7,5	241,3	222,3	9,5	8	120	73	65
120.1 - 08.0	50	8,0	263,5	244,5	11,0	6	120	73	65
120.1 - 10.0	50	10,0	314,3	295,3	11,0	8	120	73	65
160.1 - 06.5	70	6,5	215,9	200,0	9,5	6	160	100	90
160.1 - 07.5	70	7,5	241,3	222,3	9,5	8	160	100	90
160.1 - 08.0	70	8,0	263,5	244,5	11,0	6	160	100	90
160.1 - 10.0	70	10,0	314,3	295,3	11,0	8	160	100	90
200.1 - 07.5	90	7,5	241,3	222,3	9,5	8	200	129	115
200.1 - 08.0	90	8,0	263,5	244,5	11,0	6	200	129	115
200.1 - 10.0	90	10,0	314,3	295,3	11,0	8	200	129	115
200.1 - 11.5	90	11,5	352,4	333,7	11,0	8	200	129	115
260.1 - 10.0	115	10,0	314,3	295,3	11,0	8	260	165	140
260.1 - 11.5	115	11,5	352,4	333,7	11,0	8	260	165	140
260.1 - 14.0	115	14,0	466,7	438,2	14,5	8	260	165	140
260.1 - 16.0	115	16,0	517,5	489,0	14,5	8	260	165	140
320.1 - 14.0	145	14,0	466,7	438,2	14,5	8	320	210	175
320.1 - 16.0	145	16,0	517,5	489,0	14,5	8	320	210	175
320.1 - 18.0	145	18,0	571,5	542,9	18,0	6	320	210	175
400.1 - 16.0	185	16,0	517,5	489,0	14,5	8	400	275	230
400.1 - 18.0	185	18,0	571,5	542,9	18,0	6	400	275	230
400.1 - 21.0	185	21,0	673,1	641,4	18,0	12	400	275	230
400.1 - 24.0	185	24,0	733,4	692,2	22,0	12	400	275	230
500.1 - 21.0	230	21,0	673,1	641,4	18,0	12	500	335	300
500.1 - 24.0	230	24,0	733,4	692,2	22,0	12	500	335	300

To continue see next page

### Torsional Highflex Couplings RINGFEDER® TNR 2424.1

Size	L	E	F <sub>E</sub>	F <sub>K</sub>	X <sub>1</sub>	J <sub>F</sub>	J <sub>N</sub> <sup>1)</sup>	G <sub>wub</sub> <sup>1)</sup>
	mm	mm	mm	mm	mm	10 <sup>-3</sup> kgm <sup>2</sup>	10 <sup>-3</sup> kgm <sup>2</sup>	kg
120.1 - 06.5	84	4,0	+/-1,0	13	28	6	2	4,1
120.1 - 07.5	84	4,0	+/-1,0	13	28	9	2	4,4
120.1 - 08.0	84	4,0	+/-1,0	13	28	12	2	4,7
120.1 - 10.0	84	4,0	+/-1,0	13	28	26	2	5,4
160.1 - 06.5	111	4,0	+/-1,0	15	23	9	11	8,6
160.1 - 07.5	111	4,0	+/-1,0	15	23	12	11	8,9
160.1 - 08.0	111	4,0	+/-1,0	15	23	16	11	9,2
160.1 - 10.0	111	4,0	+/-1,0	15	23	31	11	10,1
200.1 - 07.5	140	5,0	+/-1,5	18	28	23	35	16,9
200.1 - 08.0	140	5,0	+/-1,5	18	28	28	35	17,3
200.1 - 10.0	140	5,0	+/-1,5	18	28	45	35	18,4
200.1 - 11.5	140	5,0	+/-1,5	18	28	66	35	19,3
260.1 - 10.0	172	6,0	+/-1,5	24	40	92	116	35,0
260.1 - 11.5	172	6,0	+/-1,5	24	40	118	116	36,3
260.1 - 14.0	172	6,0	+/-1,5	24	40	260	116	40,4
260.1 - 16.0	172	6,0	+/-1,5	24	40	381	116	42,8
320.1 - 14.0	212	7,0	+/-2,0	26	45	474	375	73,5
320.1 - 16.0	212	7,0	+/-2,0	26	45	662	375	76,6
320.1 - 18.0	212	7,0	+/-2,0	26	45	1195	375	83,0
400.1 - 16.0	271	8,0	+/-2,0	31	46	760	1274	142,0
400.1 - 18.0	271	8,0	+/-2,0	31	46	971	1274	146,0
400.1 - 21.0	271	8,0	+/-2,0	31	46	1579	1274	153,0
400.1 - 24.0	271	8,0	+/-2,0	31	46	2035	1274	158,0
500.1 - 21.0	346	10,0	+/-2,5	34	52	2402	4155	289,0
500.1 - 24.0	346	10,0	+/-2,5	34	52	2877	4155	294,0

<sup>1)</sup> Weight and moment of inertia for unbored hubs

To continue see next page

## Torsional Highflex Couplings RINGFEDER® TNR 2424.1

### Explanations

<b>d<sub>1f max</sub></b> = Max. bore diameter d <sub>1</sub> with keyway acc. to ANSI B17.1	<b>D</b> = Outer diameter	<b>F<sub>K</sub></b> = Flange thickness
<b>SAE</b> = Flange connection to SAE J 620 d	<b>D<sub>1</sub></b> = Outer diameter	<b>X<sub>1</sub></b> = Required space for dismounting of the elastic buffer
<b>A</b> = Max. outer diameter	<b>C<sub>1</sub></b> = Guided length in hub bore	<b>J<sub>F</sub></b> = Moment of inertia on thrust flange side
<b>D<sub>PC7</sub></b> = Pitch circle diameter of bore holes d <sub>7</sub>	<b>L</b> = Total length	<b>J<sub>N</sub></b> = Moment of inertia hub side
<b>d<sub>7</sub></b> = Bore diameter	<b>E</b> = Gap width between left and right component	<b>G<sub>w<sub>ub</sub></sub></b> = Weight, unbored
<b>n<sub>b7</sub></b> = Quantity of bore d <sub>7</sub>	<b>F<sub>E</sub></b> = Tolerance of the gap width E	

### Ordering example

Series	Size	Buffer	d <sub>1f</sub>	Further details <sup>*)</sup>
TNR 2424.1	200.1 - 08.0	Pb 70	80	*

<sup>\*)</sup> Without any other specification, we deliver as a standard: with set screws and keyway acc. to DIN 6885-1, keyway side fit P9, bore tolerance H7

Further information on  
**RINGFEDER® TNR 2424.1**  
 on [www.ringfeder.com](http://www.ringfeder.com)

#### Disclaimer of liability

All technical details and notes are non-binding and cannot be used as a basis for legal claims. The user is obligated to determine whether the represented products meet his requirements. We reserve the right carry out modifications at any time in the interests of technical progress.

# Torsional Highflex Couplings

## RINGFEDER® TNR 2424.2

### Two-row, SAE flange-shaft connections

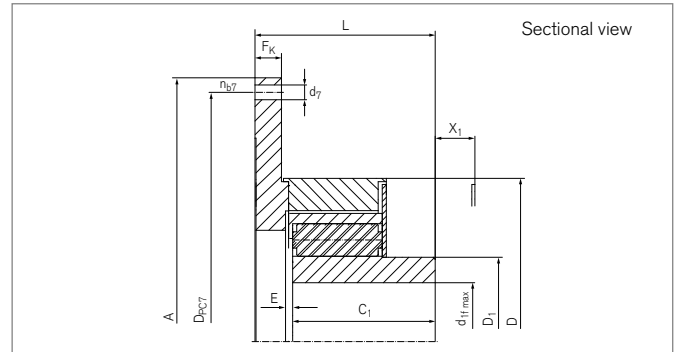

Size	$d_{1f \max}$	SAE size	A	$D_{PC7}$	$d_7$	$n_{b7}$	D	$D_1$	$C_1$
			mm	mm	mm		mm	mm	mm
160.2 - 06.5	50	6,5	215,9	200,0	9,5	6	160	73	65
160.2 - 07.5	50	7,5	241,3	222,3	9,5	8	160	73	65
160.2 - 08.0	50	8,0	263,5	244,5	11,0	6	160	73	65
160.2 - 10.0	50	10,0	314,3	295,3	11,0	8	160	73	65
200.2 - 07.5	70	7,5	222,3	213,3	9,5	8	200	100	90
200.2 - 08.0	70	8,0	263,5	244,5	11,0	6	200	100	90
200.2 - 10.0	70	10,0	314,3	295,3	11,0	8	200	100	90
200.2 - 11.5	70	11,5	352,4	333,7	11,0	8	200	100	90
260.2 - 10.0	90	10,0	314,3	295,3	11,0	8	260	129	115
260.2 - 11.5	90	11,5	352,4	333,7	11,0	8	260	129	115
260.2 - 14.0	90	14,0	466,7	438,2	14,5	8	260	129	115
260.2 - 16.0	90	16,0	517,5	489,0	14,5	8	260	129	115
320.2 - 14.0	115	14,0	466,7	438,2	14,5	8	320	165	140
320.2 - 16.0	115	16,0	517,5	489,0	14,5	8	320	165	140
320.2 - 18.0	115	18,0	571,5	542,9	18,0	6	320	165	140
400.2 - 16.0	145	16,0	517,5	489,0	14,5	8	400	208	175
400.2 - 18.0	145	18,0	571,5	542,9	18,0	6	400	208	175
400.2 - 21.0	145	21,0	673,1	641,4	18,0	12	400	208	175
400.2 - 24.0	145	24,0	733,4	692,2	22,0	12	400	208	175
500.2 - 21.0	185	21,0	673,1	641,4	18,0	12	500	268	230
500.2 - 24.0	185	24,0	733,4	692,2	22,0	12	500	268	230
640.2 - 24.0	230	24,0	733,4	692,2	22,0	12	640	335	300

To continue see next page

**Torsional Highflex Couplings RINGFEDER® TNR 2424.2**

Size	L	E	F <sub>E</sub>	F <sub>K</sub>	X <sub>1</sub>	J <sub>F</sub>	J <sub>N</sub> <sup>1)</sup>	G <sub>wub</sub> <sup>1)</sup>
	mm	mm	mm	mm	mm	10 <sup>-3</sup> kgm <sup>2</sup>	10 <sup>-3</sup> kgm <sup>2</sup>	kg
160.2 - 06.5	86	4,0	-1	15	28	10	3	5,0
160.2 - 07.5	86	4,0	-1	15	28	13	3	5,3
160.2 - 08.0	86	4,0	-1	15	28	17	3	5,6
160.2 - 10.0	86	4,0	-1	15	28	32	3	6,5
200.2 - 07.5	115	5,0	-2	18	23	21	14	10,1
200.2 - 08.0	115	5,0	-2	18	23	26	14	10,5
200.2 - 10.0	115	5,0	-2	18	23	43	14	11,6
200.2 - 11.5	115	5,0	-2	18	23	64	14	12,5
260.2 - 10.0	147	6,0	-2	24	28	86	44	21,9
260.2 - 11.5	147	6,0	-2	24	28	112	44	23,2
260.2 - 14.0	147	6,0	-2	24	28	254	44	27,3
260.2 - 16.0	147	6,0	-2	24	28	375	44	29,7
320.2 - 14.0	177	7,0	-2	26	39	464	144	47,4
320.2 - 16.0	177	7,0	-2	26	39	652	144	50,5
320.2 - 18.0	177	7,0	-2	26	39	1185	144	56,9
400.2 - 16.0	216	8,0	-2	31	51	740	462	83,4
400.2 - 18.0	216	8,0	-2	31	51	951	462	87,1
400.2 - 21.0	216	8,0	-2	31	51	1559	462	94,7
400.2 - 24.0	216	8,0	-2	31	51	2015	462	99,2
500.2 - 21.0	276	10,0	-3	34	52	2327	1544	172,0
500.2 - 24.0	276	10,0	-3	34	52	2802	1544	176,0
640.2 - 24.0	360	12,5	-5	45	60	5994	5100	340,0

<sup>1)</sup> Weight and moment of inertia for unbored hubs

To continue see next page

## Torsional Highflex Couplings RINGFEDER® TNR 2424.2

### Explanations

<b>d<sub>1f max</sub></b> = Max. bore diameter d <sub>1</sub> with keyway acc. to ANSI B17.1	<b>D</b> = Outer diameter	<b>F<sub>K</sub></b> = Flange thickness
<b>SAE</b> = Flange connection to SAE J 620 d	<b>D<sub>1</sub></b> = Outer diameter	<b>X<sub>1</sub></b> = Required space for dismounting of the elastic buffer
<b>A</b> = Max. outer diameter	<b>C<sub>1</sub></b> = Guided length in hub bore	<b>J<sub>F</sub></b> = Moment of inertia on thrust flange side
<b>D<sub>PC7</sub></b> = Pitch circle diameter of bore holes d <sub>7</sub>	<b>L</b> = Total length	<b>J<sub>N</sub></b> = Moment of inertia hub side
<b>d<sub>7</sub></b> = Bore diameter	<b>E</b> = Gap width between left and right component	<b>G<sub>W<sub>ub</sub></sub></b> = Weight, unbored
<b>n<sub>b7</sub></b> = Quantity of bore d <sub>7</sub>	<b>F<sub>E</sub></b> = Tolerance of the gap width E	

### Ordering example

Series	Size	Buffer	d <sub>1f</sub>	Further details <sup>*)</sup>
TNR 2424.2	260.2 - 14.0	Pb 70/Pb 60	80	*

<sup>\*)</sup> Without any other specification, we deliver as a standard: with set screws and keyway acc. to DIN 6885-1, keyway side fit P9, bore tolerance H7

Further information on  
**RINGFEDER® TNR 2424.2**  
 on [www.ringfeder.com](http://www.ringfeder.com)

#### Disclaimer of liability

All technical details and notes are non-binding and cannot be used as a basis for legal claims. The user is obligated to determine whether the represented products meet his requirements. We reserve the right carry out modifications at any time in the interests of technical progress.

# Torsional Highflex Couplings

## RINGFEDER® TNR 2425.1

Single-row, SAE flange-shaft connections with taper clamping bush

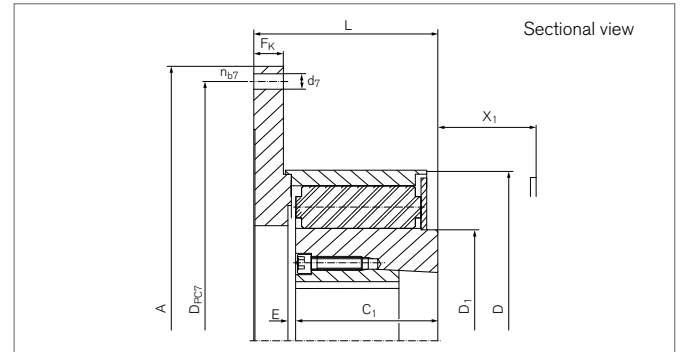

Size	Taper bushing	SAE size	A	D <sub>PC7</sub>	d <sub>7</sub>	n <sub>b7</sub>	D	D <sub>1</sub>	C <sub>1</sub>
			mm	mm	mm		mm	mm	mm
120.1 - 06.5	1615	6,5	215,9	200,0	9,5	6	120	73	52,0
120.1 - 07.5	1615	7,5	241,3	222,3	9,5	8	120	73	52,0
120.1 - 08.0	1615	8,0	263,5	244,5	11,0	6	120	73	52,0
120.1 - 10.0	1615	10,0	314,3	295,3	11,0	8	120	73	52,0
160.1 - 06.5	2012	6,5	215,9	200,0	9,5	6	160	100	64,0
160.1 - 07.5	2012	7,5	241,3	222,3	9,5	8	160	100	64,0
160.1 - 08.0	2012	8,0	263,5	244,5	11,0	6	160	100	64,0
160.1 - 10.0	2012	10,0	314,3	295,3	11,0	8	160	100	64,0
200.1 - 07.5	2517	7,5	222,3	213,3	9,5	8	200	129	80,0
200.1 - 08.0	2517	8,0	263,5	244,5	11,0	6	200	129	80,0
200.1 - 10.0	2517	10,0	314,3	295,3	11,0	8	200	129	80,0
200.1 - 11.5	2517	11,5	352,4	333,7	11,0	8	200	129	80,0
260.1 - 10.0	3535	10,0	314,3	295,3	11,0	8	260	165	100,0
260.1 - 11.5	3535	11,5	352,4	333,7	11,0	8	260	165	100,0
260.1 - 14.0	3535	14,0	466,7	438,2	14,5	8	260	165	100,0
260.1 - 16.0	3535	16,0	517,5	489,0	14,5	8	260	165	100,0
320.1 - 14.0	4040	14,0	466,7	438,2	14,5	8	320	208	125,0
320.1 - 16.0	4040	16,0	517,5	489,0	14,5	8	320	208	125,0
320.1 - 18.0	4040	18,0	571,5	542,9	18,0	6	320	208	125,0
400.1 - 16.0	5050	16,0	517,5	489,0	14,5	8	400	268	156,0
400.1 - 18.0	5050	18,0	571,5	542,9	18,0	6	400	268	156,0
400.1 - 21.0	5050	21,0	673,1	641,4	18,0	12	400	268	156,0
400.1 - 24.0	5050	24,0	733,4	692,2	22,0	12	400	268	156,0

Taper bushing bore see chapter „Ordering example“ in Product Paper & Tech Paper „RINGFEDER® Torsional Highflex Couplings“

To continue see next page

### Torsional Highflex Couplings RINGFEDER® TNR 2425.1

Size	L	E	F <sub>E</sub>	F <sub>K</sub>	X <sub>1</sub>	J <sub>F</sub>	J <sub>N</sub> <sup>1)</sup>	G <sub>wub</sub> <sup>1)</sup>
	mm	mm	mm	mm	mm	10 <sup>-3</sup> kgm <sup>2</sup>	10 <sup>-3</sup> kgm <sup>2</sup>	kg
120.1 - 06.5	71	4,0	+/- 1,0	13	41	6	1,4	2,8
120.1 - 07.5	71	4,0	+/- 1,0	13	41	9	1,4	3,1
120.1 - 08.0	71	4,0	+/- 1,0	13	41	12	1,4	3,4
120.1 - 10.0	71	4,0	+/- 1,0	13	41	26	1,4	4,1
160.1 - 06.5	84	4,0	+/- 1,0	15	50	9	7,6	5,3
160.1 - 07.5	84	4,0	+/- 1,0	15	50	12	7,6	5,6
160.1 - 08.0	84	4,0	+/- 1,0	15	50	16	7,6	5,9
160.1 - 10.0	84	4,0	+/- 1,0	15	50	31	7,6	6,8
200.1 - 07.5	104	5,0	+/- 1,5	18	64	23	24	10,2
200.1 - 08.0	104	5,0	+/- 1,5	18	64	28	24	10,6
200.1 - 10.0	104	5,0	+/- 1,5	18	64	45	24	11,6
200.1 - 11.5	104	5,0	+/- 1,5	18	64	66	24	12,6
260.1 - 10.0	132	6,0	+/- 1,5	24	80	92	80	20,3
260.1 - 11.5	132	6,0	+/- 1,5	24	80	118	80	21,5
260.1 - 14.0	132	6,0	+/- 1,5	24	80	260	80	25,6
260.1 - 16.0	132	6,0	+/- 1,5	24	80	381	80	28,0
320.1 - 14.0	162	7,0	+/- 2,0	26	100	474	275	44,6
320.1 - 16.0	162	7,0	+/- 2,0	26	100	662	275	47,2
320.1 - 18.0	162	7,0	+/- 2,0	26	100	1195	275	50,3
400.1 - 16.0	197	8,0	+/- 2,0	31	126	760	897	83,9
400.1 - 18.0	197	8,0	+/- 2,0	31	126	971	897	87,6
400.1 - 21.0	197	8,0	+/- 2,0	31	126	1579	897	95,2
400.1 - 24.0	197	8,0	+/- 2,0	31	126	2035	897	99,7

<sup>1)</sup> Weight and mass moment of inertia for hubs without taper lock bushing

### Explanations

<b>SAE</b> = Flange connection to SAE J 620 d	<b>D<sub>1</sub></b> = Outer diameter	<b>X<sub>1</sub></b> = Required space for dismounting of the elastic buffer
<b>A</b> = Max. outer diameter	<b>C<sub>1</sub></b> = Guided length in hub bore	<b>J<sub>F</sub></b> = Moment of inertia on thrust flange side
<b>D<sub>PC7</sub></b> = Pitch circle diameter of bore holes d <sub>7</sub>	<b>L</b> = Total length	<b>J<sub>N</sub></b> = Moment of inertia hub side
<b>d<sub>7</sub></b> = Bore diameter	<b>E</b> = Gap width between left and right component	<b>G<sub>wub</sub></b> = Weight, unbored
<b>n<sub>b7</sub></b> = Quantity of bore d <sub>7</sub>	<b>F<sub>E</sub></b> = Tolerance of the gap width E	
<b>D</b> = Outer diameter	<b>F<sub>K</sub></b> = Flange thickness	

### Ordering example

Series	Size	Buffer	Taper bushing	Bore taper bushing
TNR 2425.1	200.1 - 08.0	Pb 70	2517	28

Further information on  
**RINGFEDER® TNR 2425.1**  
 on [www.ringfeder.com](http://www.ringfeder.com)

#### Disclaimer of liability

All technical details and notes are non-binding and cannot be used as a basis for legal claims. The user is obligated to determine whether the represented products meet his requirements. We reserve the right carry out modifications at any time in the interests of technical progress.



# Torsional Highflex Couplings

## RINGFEDER® TNR 2425.2

Two-row, SAE flange-shaft connections with taper clamping bush

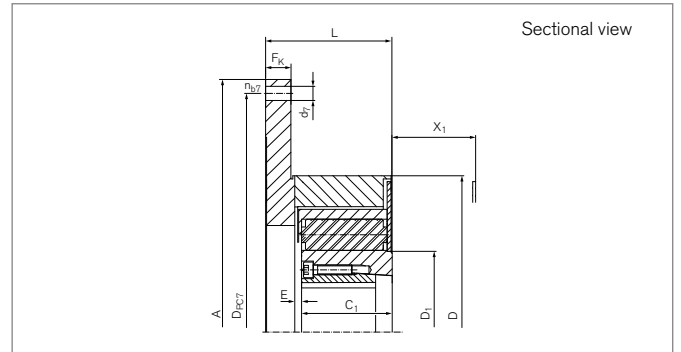

Size	Taper bushing	SAE Size	A	D <sub>PC7</sub>	d <sub>7</sub>	n <sub>b7</sub>	D	D <sub>1</sub>	C <sub>1</sub>
			mm	mm	mm		mm	mm	mm
160.2 - 06.5	1615	6,5	215,9	200,0	9,5	6	160	73	52,0
160.2 - 07.5	1615	7,5	241,3	222,3	9,5	8	160	73	52,0
160.2 - 08.0	1615	8,0	263,5	244,5	11,0	6	160	73	52,0
160.2 - 10.0	1615	10,0	314,3	295,3	11,0	8	160	73	52,0
200.2 - 07.5	2012	7,5	222,3	213,3	9,5	8	200	100	64,0
200.2 - 08.0	2012	8,0	263,5	244,5	11,0	6	200	100	64,0
200.2 - 10.0	2012	10,0	314,3	295,3	11,0	8	200	100	64,0
200.2 - 11.5	2012	11,5	352,4	333,7	11,0	8	200	100	64,0
260.2 - 10.0	2517	10,0	314,3	295,3	11,0	8	260	129	80,0
260.2 - 11.5	2517	11,5	352,4	333,7	11,0	8	260	129	80,0
260.2 - 14.0	2517	14,0	466,7	438,2	14,5	8	260	129	80,0
260.2 - 16.0	2517	16,0	517,5	489,0	14,5	8	260	129	80,0
320.2 - 14.0	3535	14,0	466,7	438,2	14,5	8	320	165	100,0
320.2 - 16.0	3535	16,0	517,5	489,0	14,5	8	320	165	100,0
320.2 - 18.0	3535	18,0	571,5	542,9	18,0	6	320	165	100,0
400.2 - 16.0	4040	16,0	517,5	489,0	14,5	8	400	208	125,0
400.2 - 18.0	4040	18,0	571,5	542,9	18,0	6	400	208	125,0
400.2 - 21.0	4040	21,0	673,1	641,4	18,0	12	400	208	125,0
400.2 - 24.0	4040	24,0	733,4	692,2	22,0	12	400	208	125,0
500.2 - 21.0	5050	21,0	673,1	641,4	18,0	12	500	268	156,0
500.2 - 24.0	5050	24,0	733,4	692,2	22,0	12	500	268	156,0

Taper bushing bore see chapter „Ordering example“ in Product Paper & Tech Paper „RINGFEDER® Torsional Highflex Couplings“

To continue see next page

**Torsional Highflex Couplings RINGFEDER® TNR 2425.2**

Size	L	E	F <sub>E</sub>	F <sub>K</sub>	X <sub>1</sub>	J <sub>F</sub>	J <sub>N</sub> <sup>1)</sup>	G <sub>wub</sub> <sup>1)</sup>
	mm	mm	mm	mm	mm	10 <sup>-3</sup> kgm <sup>2</sup>	10 <sup>-3</sup> kgm <sup>2</sup>	kg
160.2 - 06.5	71	4,0	-1,0	15	41	10	9	3,7
160.2 - 07.5	71	4,0	-1,0	15	41	13	12	4,0
160.2 - 08.0	71	4,0	-1,0	15	41	17	16	4,3
160.2 - 10.0	71	4,0	-1,0	15	41	32	31	5,2
200.2 - 07.5	84	5,0	-1,5	18	50	21	18	6,8
200.2 - 08.0	84	5,0	-1,5	18	50	26	23	7,2
200.2 - 10.0	84	5,0	-1,5	18	50	43	40	8,3
200.2 - 11.5	84	5,0	-1,5	18	50	64	61	9,2
260.2 - 10.0	104	6,0	-1,5	24	64	86	76	15,2
260.2 - 11.5	104	6,0	-1,5	24	64	112	102	16,4
260.2 - 14.0	104	6,0	-1,5	24	64	254	244	20,5
260.2 - 16.0	104	6,0	-1,5	24	64	375	365	22,9
320.2 - 14.0	132	7,0	-2,0	26	80	464	302	30,1
320.2 - 16.0	132	7,0	-2,0	26	80	652	428	32,7
320.2 - 18.0	132	7,0	-2,0	26	80	1185	616	35,7
400.2 - 16.0	162	8,0	-2,0	31	100	740	640	57,1
400.2 - 18.0	162	8,0	-2,0	31	31	951	851	60,7
400.2 - 21.0	162	8,0	-2,0	31	100	1559	1459	68,4
400.2 - 24.0	162	8,0	-2,0	31	100	2015	1915	72,8
500.2 - 21.0	197	10,0	-2,5	34	126	2327	1950	114,0
500.2 - 24.0	197	10,0	-2,5	34	126	2802	2425	118,0

<sup>1)</sup> Weight and mass moment of inertia for hubs without taper lock bushing

## Explanations

<b>SAE</b> = Flange connection to SAE J 620 d	<b>D<sub>1</sub></b> = Outer diameter	<b>X<sub>1</sub></b> = Required space for dismounting of the elastic buffer
<b>A</b> = Max. outer diameter	<b>C<sub>1</sub></b> = Guided length in hub bore	<b>J<sub>F</sub></b> = Moment of inertia on thrust flange side
<b>D<sub>PC7</sub></b> = Pitch circle diameter of bore holes d <sub>7</sub>	<b>L</b> = Total length	<b>J<sub>N</sub></b> = Moment of inertia hub side
<b>d<sub>7</sub></b> = Bore diameter	<b>E</b> = Gap width between left and right component	<b>G<sub>wub</sub></b> = Weight, unbored
<b>n<sub>b7</sub></b> = Quantity of bore d <sub>7</sub>	<b>F<sub>E</sub></b> = Tolerance of the gap width E	
<b>D</b> = Outer diameter	<b>F<sub>K</sub></b> = Flange thickness	

## Ordering example

Series	Size	Buffer	Taper bushing	Bore taper bushing
TNR 2425.2	260.2 - 14.0	Pb 70/Pb 60	2517	28

Further information on  
**RINGFEDER® TNR 2425.2**  
 on [www.ringfeder.com](http://www.ringfeder.com)

### Disclaimer of liability

All technical details and notes are non-binding and cannot be used as a basis for legal claims. The user is obligated to determine whether the represented products meet his requirements. We reserve the right carry out modifications at any time in the interests of technical progress.

# Torsional Highflex Couplings

## RINGFEDER® TNR 2428.1

### Single-row, shaft-shaft connections

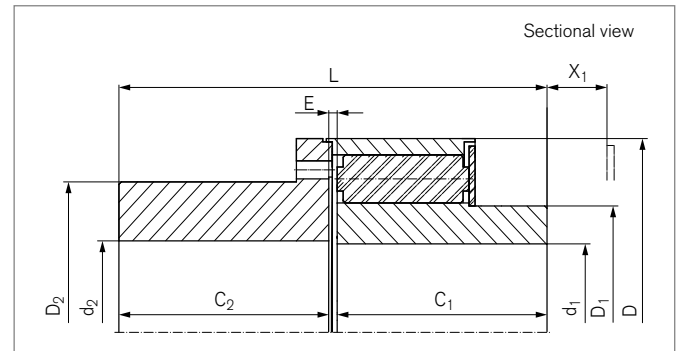

Size	$d_{1f \max}$	$d_{2f \max}$	D	D <sub>1</sub>	D <sub>2</sub>	C <sub>1</sub>	C <sub>2</sub>
	mm	mm	mm	mm	mm	mm	mm
120.1	50	55	120	73	85	65	65
160.1	70	75	160	100	115	90	90
200.1	90	105	200	129	155	115	115
260.1	115	130	260	165	195	140	140
320.1	145	165	320	210	245	175	175
400.1	185	215	400	275	305	230	230
500.1	230	250	500	335	350	300	300
640.1	300	320	640	430	450	380	380

Size	L	E	F <sub>E</sub>	X <sub>1</sub>	J <sub>F</sub>	J <sub>N</sub> <sup>1)</sup>	G <sub>wub</sub> <sup>1)</sup>
	mm	mm	mm	mm	10 <sup>-3</sup> kgm <sup>2</sup>	10 <sup>-3</sup> kgm <sup>2</sup>	kg
120.1	134	4	+/- 1,0	28	5	2	6,7
160.1	184	4	+/- 1,0	23	23	11	16,3
200.1	235	5	+/- 1,5	28	83	35	34,9
260.1	286	6	+/- 1,5	40	274	116	69,7
320.1	357	7	+/- 2,0	50	804	375	137,0
400.1	468	8	+/- 2,0	52	2383	1274	278,0
500.1	610	10	+/- 2,5	60	6175	4155	527,0
640.1	775	15	+/- 4,5	68	21314	13355	1088,0

<sup>1)</sup> Weight and moment of inertia for unbored hubs

To continue see next page

## Torsional Highflex Couplings RINGFEDER® TNR 2428.1

### Explanations

<b>d<sub>1f max</sub></b> = Max. bore diameter d <sub>1</sub> with keyway acc. to ANSI B17.1	<b>D<sub>2</sub></b> = Outer diameter hub	<b>F<sub>E</sub></b> = Tolerance of the gap width E
<b>d<sub>2f max</sub></b> = Max. bore diameter d <sub>2</sub> with keyway acc. to ANSI B17.1	<b>C<sub>1</sub></b> = Guided length in hub bore	<b>X<sub>1</sub></b> = Required space for dismounting of the elastic buffer
<b>D</b> = Outer diameter	<b>C<sub>2</sub></b> = Guided length in hub bore	<b>J<sub>F</sub></b> = Moment of inertia on thrust flange side
<b>D<sub>1</sub></b> = Outer diameter	<b>L</b> = Total length	<b>J<sub>N</sub></b> = Moment of inertia hub side
	<b>E</b> = Gap width between left and right component	<b>G<sub>wub</sub></b> = Weight, unbored

### Ordering example

Series	Size	Buffer	d <sub>1f</sub>	d <sub>2f</sub>	Further details <sup>*)</sup>
TNR 2428.1	260.1	Vk 90	100	90	*

<sup>\*)</sup> Without any other specification, we deliver as a standard: with set screws and keyway acc. to DIN 6885-1, keyway side fit P9, bore tolerance H7

Further information on  
**RINGFEDER® TNR 2428.1**  
 on [www.ringfeder.com](http://www.ringfeder.com)

#### Disclaimer of liability

All technical details and notes are non-binding and cannot be used as a basis for legal claims. The user is obligated to determine whether the represented products meet his requirements. We reserve the right carry out modifications at any time in the interests of technical progress.

# Torsional Highflex Couplings

## RINGFEDER® TNR 2428.2

### Two-row, shaft-shaft connections

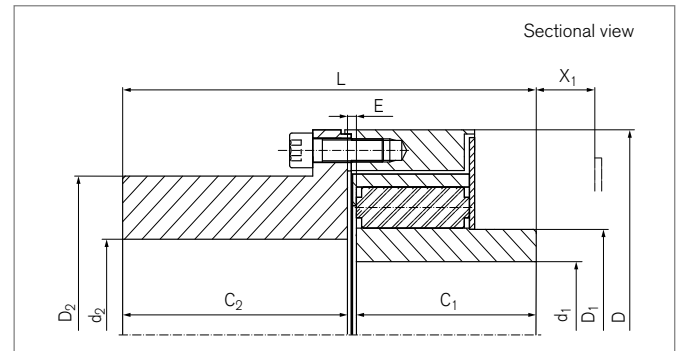

Size	$d_{1f \max}$	$d_{2f \max}$	D	$D_1$	$D_2$	$C_1$	$C_2$
	mm	mm	mm	mm	mm	mm	mm
160.2	50	75	160	73	115	65	90
200.2	70	105	200	100	155	90	115
260.2	90	130	260	129	195	115	140
320.2	115	165	320	165	245	140	175
400.2	145	215	400	210	305	175	230
500.2	185	250	500	275	350	230	300
640.2	230	320	640	335	450	300	380

Size	L	E	$F_E$	$X_1$	$J_F$	$J_N^{1)}$	$G_{W_{ub}}^{1)}$
	mm	mm	mm	mm	$10^{-3} \text{kgm}^2$	$10^{-3} \text{kgm}^2$	kg
160.2	159	4	-1,0	28	23	3	12,8
200.2	210	5	-1,5	23	81	14	28,1
260.2	261	6	-1,5	28	268	44	56,6
320.2	322	7	-2,0	40	794	144	110,0
400.2	413	8	-2,0	50	2363	462	219,0
500.2	540	10	-2,5	52	6100	1544	409,0
640.2	695	15	-4,5	60	21052	5100	855,0

<sup>1)</sup> Weight and moment of inertia for unbored hubs

To continue see next page

## Torsional Highflex Couplings RINGFEDER® TNR 2428.2

### Explanations

<b>d<sub>1f max</sub></b> = Max. bore diameter d <sub>1</sub> with keyway acc. to ANSI B17.1	<b>D<sub>2</sub></b> = Outer diameter hub	<b>F<sub>E</sub></b> = Tolerance of the gap width E
<b>d<sub>2f max</sub></b> = Max. bore diameter d <sub>2</sub> with keyway acc. to ANSI B17.1	<b>C<sub>1</sub></b> = Guided length in hub bore	<b>X<sub>1</sub></b> = Required space for dismounting of the elastic buffer
<b>D</b> = Outer diameter	<b>C<sub>2</sub></b> = Guided length in hub bore	<b>J<sub>F</sub></b> = Moment of inertia on thrust flange side
<b>D<sub>1</sub></b> = Outer diameter	<b>L</b> = Total length	<b>J<sub>N</sub></b> = Moment of inertia hub side
	<b>E</b> = Gap width between left and right component	<b>G<sub>w<sub>ub</sub></sub></b> = Weight, unbored

### Ordering example

Series	Size	Buffer	d <sub>1f</sub>	d <sub>2f</sub>	Further details*)
TNR 2428.2	260.2	Vk 90/Vk 80	80	120	*

\*) Without any other specification, we deliver as a standard: with set screws and keyway acc. to DIN 6885-1, keyway side fit P9, bore tolerance H7

Further information on  
**RINGFEDER® TNR 2428.2**  
 on [www.ringfeder.com](http://www.ringfeder.com)

#### Disclaimer of liability

All technical details and notes are non-binding and cannot be used as a basis for legal claims. The user is obligated to determine whether the represented products meet his requirements. We reserve the right carry out modifications at any time in the interests of technical progress.